



三合微科股份有限公司  
SAMHOP Microelectronics Corp.

---

# SM7346A

## 6 CHANNELS VOLUME CONTROLLER

REV. 3.10

DECEMBER 22, 2004

**The information in this document is subject to change without notice.  
© SAMHOP Microelectronics Corp. All Rights Reserved.**

---

台北縣新店市民權路100號7樓  
7F, No. 100, Min-Chyuan Road, Hsintien, Taipei Hsien, Taiwan, R.O.C.  
TEL: 886-2-2218-3978/2820 FAX: 886-2-2218-3320  
E-mail : [info@samhop.com.tw](mailto:info@samhop.com.tw)



### 6 CHANNELS VOLUME CONTROLLER

#### GENERAL DESCRIPTION

The SM7346A is 6 channels electronic volume controlled by 3-wire serial data. The IC is suitable for use in DVD systems and AV.

#### APPLICATIONS

- \* DVD Receivers
- \* Home Audio Equipment
- \* AV

#### FEATURES

- \* 4 Output ports
- \* Built-in microcomputer interface circuit controlled by 16-bit serial data.
- \* Electronic volume  
Volume level: 0dB~-95dB, -∞dB(1dB/step)
- \* Tone control  
Bass/Treble, 0dB~±14dB(2dB/step)

#### PIN ASSIGNMENTS

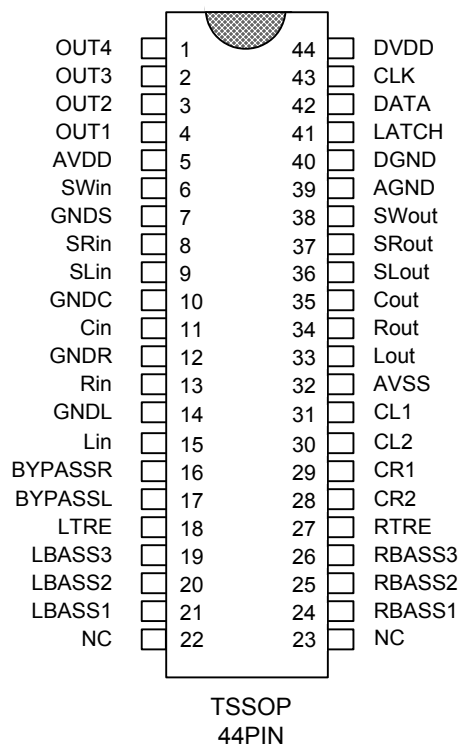
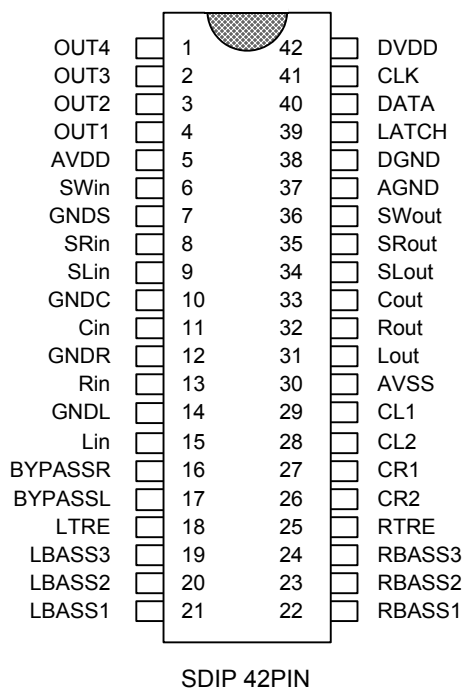



6 CHANNELS VOLUME CONTROLLER

BLOCK DIAGRAM

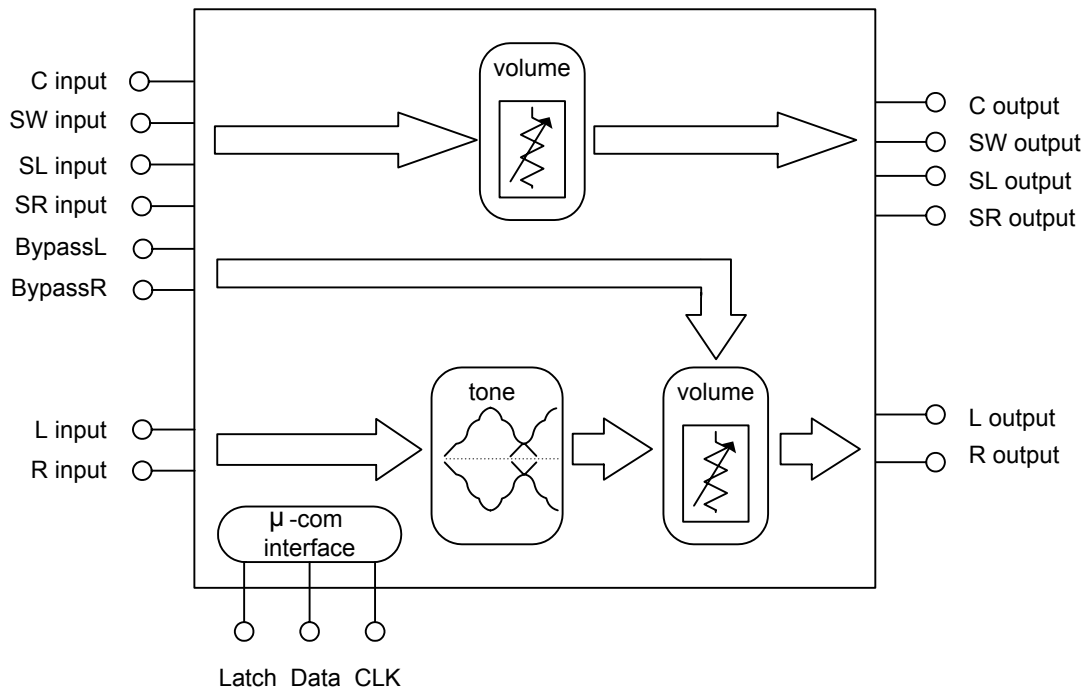



**6 CHANNELS VOLUME CONTROLLER**

**PIN DESCRIPTION (Pin count base on 42pin SDIP)**

Pin No.	Symbol	Function	Circuit
1	OUT4	Port OUTPUT	OUTPUT: PMOS Transistor open drain 
2	OUT3		
3	OUT2		
4	OUT1		
5	AVDD	Analog positive Power supply	+7V
7	GNDS	GND	Connect to analog GND
10	GNDC		
12	GNDR		
14	GNDL		
6	SW in	Volume INPUT	
8	SR in		
9	SL in		
11	C in		
36	SW out	Volume OUTPUT	
35	SR out		
34	SL out		
33	C out		
13	R in	Tone INPUT	
15	L in		
16	BYPASSR	L.R Volume INPUT in BYPASS mode	
17	BYPASSL		
31	L out	L OUTPUT	
32	R out	R OUTPUT	
18	LTRE	Tone Treble cycle control	
25	RTRE		
19	LBASS3	Tone Bass cycle control	
24	RBASS3		
20	LBASS2		
23	RBASS2		
21	LBASS1		
22	RBASS1		
26	CR2	Tone OUTPUT	
28	CL2		
27	CR1	L.R Volume INPUT	
29	CL1		
31	L out	L OUTPUT	
32	R out	R OUTPUT	
30	AVSS	Analog negative Power supply	-7V
37	AGND	Analog GND	
38	DGND	Digital GND	
39	LATCH	Latch INPUT	
40	DATA	Data INPUT	
41	CLK	Clock INPUT Forward data	
42	DVDD	Digital Power supply	+5V



6 CHANNELS VOLUME CONTROLLER

PIN CONFIGURATION AND IC INTERNAL BLOCK DIAGRAM ( Pin count base on 42pin )

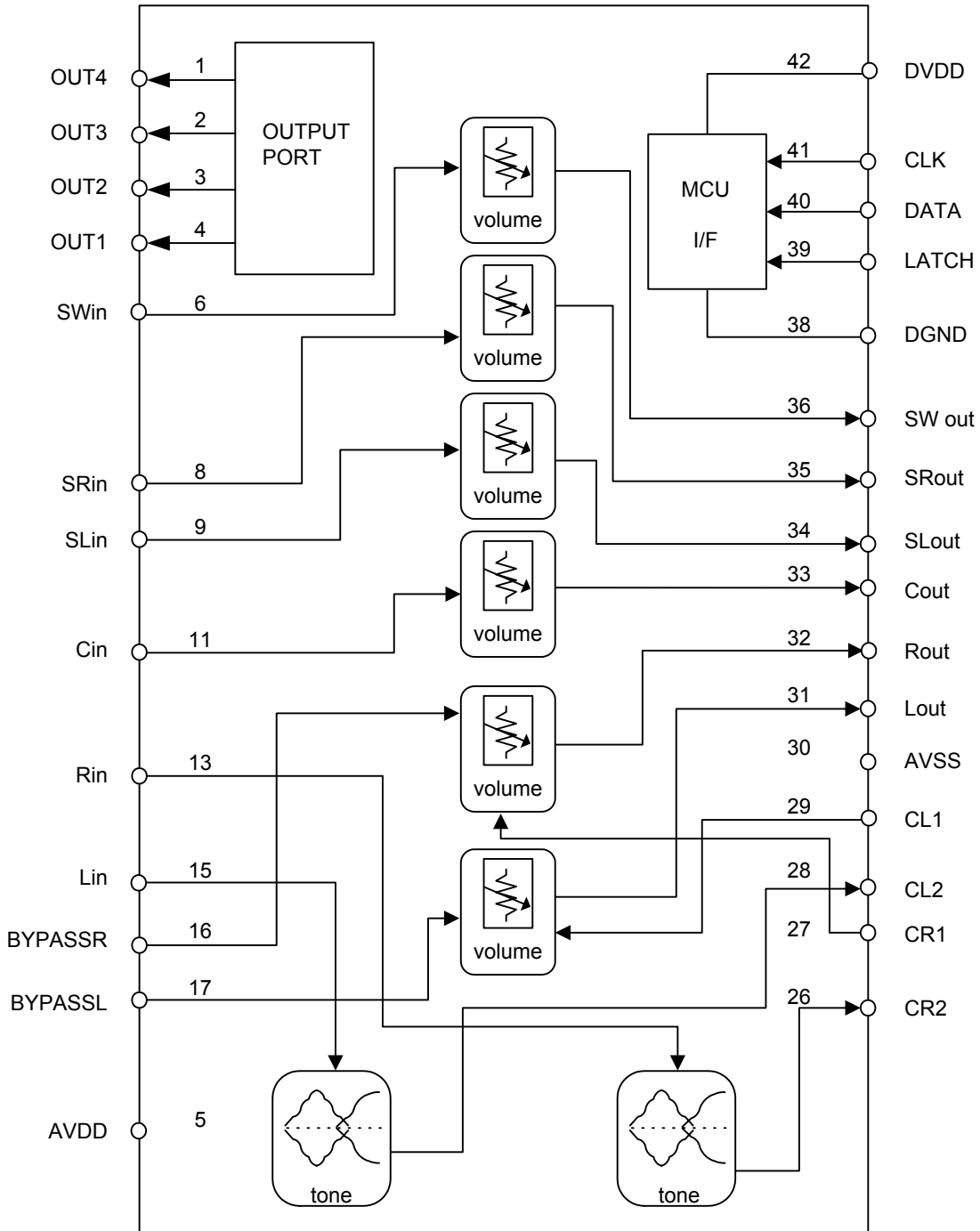

**6 CHANNELS VOLUME CONTROLLER****ABSOLUTE MAXIMUM RATINGS**

Symbol	Parameter	Conditions	Ratings	Unit
Vsupply	Supply Voltage	AVDD-AVSS	16.0	V
Pd	Power dissipation	Ta $\leq$ 25°C	1000	mW
K $_{\theta}$	Thermal derating	Ta>25°C *standard board	10	mW / °C
Topr	Operating temperature		-20~+75	°C
Tstg	Storage temperature		-40~+125	°C

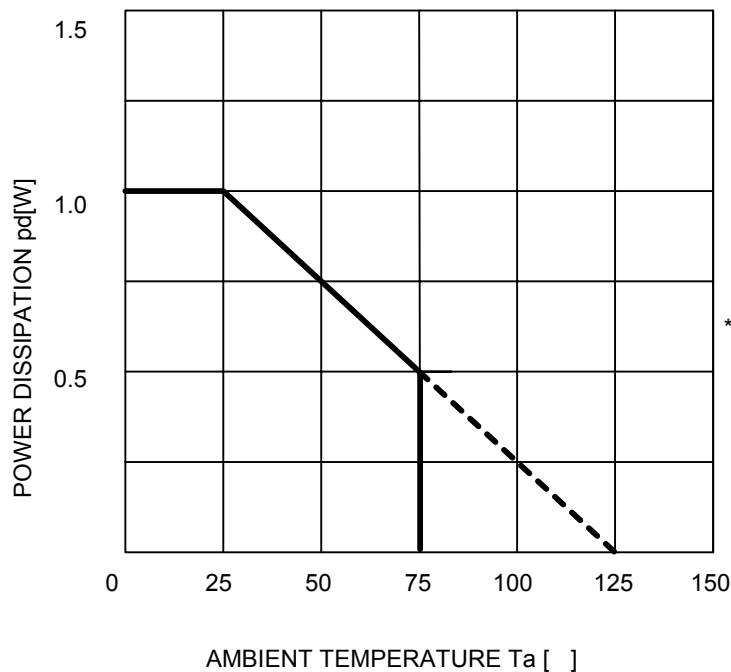
**THERMAL DERATING (MAXIMUM RATING)  
Standard board**

\* Standard board  
board size :70mm X 70mm  
board thickness :1.6mm  
board material :glass epoxy  
copper pattern :  
copper thickness:18um  
copper size :0.25mm(wide)  
30mm(length/lead)



6 CHANNELS VOLUME CONTROLLER

RECOMMENDED OPERATING CONDITION

Parameter	Symbol	Condition	Min.	Typ.	Max.	Unit
Analog positive Supply Voltage	AVDD		6.0	7.0	8.0	V
Analog negative Supply Voltage	AVSS		- 8.0	- 7.0	- 6.0	V
Digital Supply Voltage	DVDD		4.5	5.0	5.5	V
High-level Input Voltage	VIH		DVDDX0.7	-	DVDD	V
Low-level Input Voltage	VIL		DGND	-	DVDDX0.3	V

Note1 :  $AVSS \leq DGND < DVDD \leq AVDD$  or  $AVSS \leq DGND < AVDD \leq DVDD$

Note2 :  $AGND = (AVSS + AVDD) / 2$

DATA TIMING(Recommended conditions)

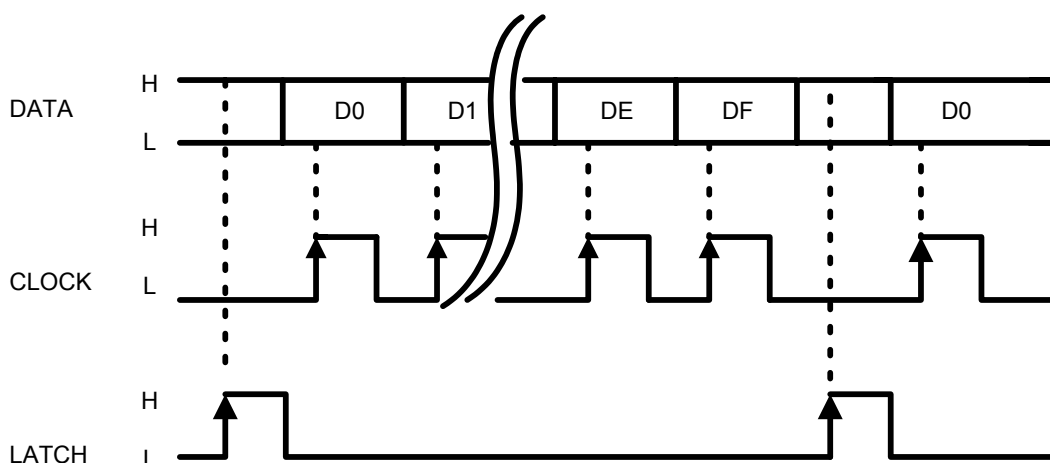

Note: CLOCK and LATCH function at raising edges of pulse.



6 CHANNELS VOLUME CONTROLLER

CLOCK, DATA, LATCH TIMING

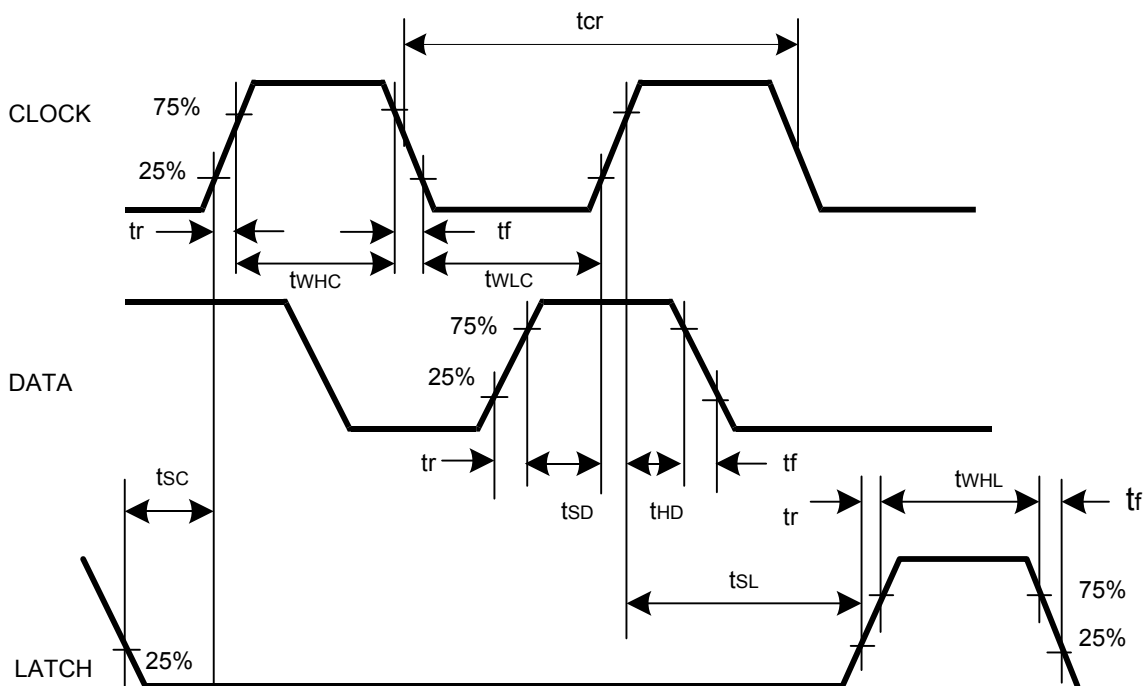

DIGITAL BLOCK TIMING REGULATION

Symbol	Parameter	Limits			Unit
		Min	Typ	Max	
$t_{cr}$	CLOCK cycle time	8	—	—	$\mu$ sec
$t_{wHC}$	CLOCK pulse width("H"level)	3.2	—	—	
$t_{wLC}$	CLOCK pulse width("L"level)	3.2	—	—	
$t_r$	CLOCK,DATA,LATCH rise time	—	—	0.8	
$t_f$	CLOCK,DATA,LATCH fall time	—	—	0.8	
$t_{SD}$	DATA setup time	1.6	—	—	
$t_{HD}$	DATA hold time	1.6	—	—	
$t_{SL}$	LATCH setup time	2	—	—	
$t_{wHL}$	LATCH pulse width	3.2	—	—	
$t_{sc}$	CLOCK start time after LATCH	3.2	—	—	



**6 CHANNELS VOLUME CONTROLLER**

**DIGITAL CONTROL SPECIFICATION**

Four kinds of input format options are available by changing slot settings of DE and DF.

- ( 1 )
 

D01	D11	D21	D31	D41	D51	D61	D71	D81	D91	DA1	DB1	DC1	DD1	DE	DF
TONE CONTROL TREBLE				1	2	3	4	TONE CONTROL BASS				0	BY PASS 1:ON 0:OFF	0	0
				OUTPUT PORT 1:High 0:Low											
  
- ( 2 )
 

D02	D12	D22	D32	D42	D52	D62	D72	D82	D92	DA2	DB2	DC2	DD2	DE	DF
VOLUME Lch								VOLUME Rch						0	1
  
- ( 3 )
 

D03	D32	D23	D33	D43	D53	D63	D73	D83	D93	DA3	DB3	DC3	DD3	DE	DF
VOLUME Cch								VOLUME SWch						1	0
  
- ( 4 )
 

D04	D14	D24	D34	D44	D54	D64	D74	D84	D94	DA4	DB4	DC4	DD4	DE	DF
VOLUME SLch								VOLUME SRch						1	1

NOTE : When the IC is powered up, the internal setting of channel output are fixed to  $-\infty$ .



**6 CHANNELS VOLUME CONTROLLER**

**SETTING CODE**

**(1) Tone Control ( bass / treble )**

ATT	treble	D01	D11	D21	D31
	bass	D81	D91	DA1	DB1
-14dB		1	1	1	1
-12dB		1	1	0	1
-10dB		1	1	1	0
-8dB		1	1	0	0
-6dB		1	0	1	1
-4dB		1	0	1	0
-2dB		1	0	0	1
+0dB		0	0	0	0
+2dB		0	0	0	1
+4dB		0	0	1	0
+6dB		0	0	1	1
+8dB		0	1	0	0
+10dB		0	1	1	0
+12dB		0	1	0	1
+14dB		0	1	1	1

**(2) Port output**

D41, D51, D61, D71	
Out: L	0
Out: H	1

**(3) BYPASS control**

DD1	
TONE	0
BYPASS	1

Note: Do not input other data than the above.



**6 CHANNELS VOLUME CONTROLLER**

**(4)-1 Volume ( 0~-39dB )**

Note: Do not input other data than the above.

A T T	Volume		D0X	D1X	D2X	D3X	D4X	D5X	D6X
			D7X	D8X	D9X	DAX	DBX	DCX	DDX
-	0	dB	0	0	0	0	0	0	0
-	1	dB	0	0	0	0	0	0	1
-	2	dB	0	0	0	0	0	1	0
-	3	dB	0	0	0	0	0	1	1
-	4	dB	0	0	0	0	1	0	0
-	5	dB	0	0	0	0	1	0	1
-	6	dB	0	0	0	0	1	1	0
-	7	dB	0	0	0	0	1	1	1
-	8	dB	0	0	0	1	0	0	0
-	9	dB	0	0	0	1	0	0	1
-	10	dB	0	0	0	1	0	1	0
-	11	dB	0	0	0	1	0	1	1
-	12	dB	0	0	0	1	1	0	0
-	13	dB	0	0	0	1	1	0	1
-	14	dB	0	0	0	1	1	1	0
-	15	dB	0	0	0	1	1	1	1
-	16	dB	0	0	1	0	0	0	0
-	17	dB	0	0	1	0	0	0	1
-	18	dB	0	0	1	0	0	1	0
-	19	dB	0	0	1	0	0	1	1
-	20	dB	0	0	1	0	1	0	0
-	21	dB	0	0	1	0	1	0	1
-	22	dB	0	0	1	0	1	1	0
-	23	dB	0	0	1	0	1	1	1
-	24	dB	0	0	1	1	0	0	0
-	25	dB	0	0	1	1	0	0	1
-	26	dB	0	0	1	1	0	1	0
-	27	dB	0	0	1	1	0	1	1
-	28	dB	0	0	1	1	1	0	0
-	29	dB	0	0	1	1	1	0	1
-	30	dB	0	0	1	1	1	1	0
-	31	dB	0	0	1	1	1	1	1
-	32	dB	0	1	0	0	0	0	0
-	33	dB	0	1	0	0	0	0	1
-	34	dB	0	1	0	0	0	1	0
-	35	dB	0	1	0	0	0	1	1
-	36	dB	0	1	0	0	1	0	0
-	37	dB	0	1	0	0	1	0	1
-	38	dB	0	1	0	0	1	1	0
-	39	dB	0	1	0	0	1	1	1



**6 CHANNELS VOLUME CONTROLLER**

(4)-2 VOLUME ( - 40 ~ - ∞ dB )

Note: Do not input other data than the above.

A T T	Volume		D0X	D1X	D2X	D3X	D4X	D5X	D6X
			D7X	D8X	D9X	DAX	DBX	DCX	DDX
-	40	dB	0	1	0	1	0	0	0
-	41	dB	0	1	0	1	0	0	1
-	42	dB	0	1	0	1	0	1	0
-	43	dB	0	1	0	1	0	1	1
-	44	dB	0	1	0	1	1	0	0
-	45	dB	0	1	0	1	1	0	1
-	46	dB	0	1	0	1	1	1	0
-	47	dB	0	1	0	1	1	1	1
-	48	dB	0	1	1	0	0	0	0
-	49	dB	0	1	1	0	0	0	1
-	50	dB	0	1	1	0	0	1	0
-	51	dB	0	1	1	0	0	1	1
-	52	dB	0	1	1	0	1	0	0
-	53	dB	0	1	1	0	1	0	1
-	54	dB	0	1	1	0	1	1	0
-	55	dB	0	1	1	0	1	1	1
-	56	dB	0	1	1	1	0	0	0
-	57	dB	0	1	1	1	0	0	1
-	58	dB	0	1	1	1	0	1	0
-	59	dB	0	1	1	1	0	1	1
-	60	dB	0	1	1	1	1	0	0
-	61	dB	0	1	1	1	1	0	1
-	62	dB	0	1	1	1	1	1	0
-	63	dB	0	1	1	1	1	1	1
-	64	dB	1	0	0	0	0	0	0
-	65	dB	1	0	0	0	0	0	1
-	66	dB	1	0	0	0	0	1	0
-	67	dB	1	0	0	0	0	1	1
-	68	dB	1	0	0	0	1	0	0
-	69	dB	1	0	0	0	1	0	1
-	70	dB	1	0	0	0	1	1	0
-	71	dB	1	0	0	0	1	1	1
-	72	dB	1	0	0	1	0	0	0
-	73	dB	1	0	0	1	0	0	1
-	74	dB	1	0	0	1	0	1	0
-	75	dB	1	0	0	1	0	1	1
-	76	dB	1	0	0	1	1	0	0
-	77	dB	1	0	0	1	1	0	1
-	78	dB	1	0	0	1	1	1	0
-	79	dB	1	0	0	1	1	1	1
-	∞	dB	1	0	1	0	0	0	0



**6 CHANNELS VOLUME CONTROLLER****ELECTRICAL CHARACTERISTICS**

( Ta=25 ,AVDD=7.0V, AVSS=-7.0V, DVDD=5.0V, f=1kHz, unless otherwise noted. Rg=1KΩ, RI=10KΩ, TONE CONTROL, VOLUME are set to 0dB/FLAT )

**(1)Power Supply Characteristics ( Pin count base on 42pin version )**

Parameter	Symbol	Test condition	Limits			Unit
			Min	typ	Max	
Analog positive circuit current	Aldd	Current at pin 5 No signal	-	24	35	mA
Analog negative circuit current	Alss	Current at pin 30 No signal	-	24	35	mA
Digital circuit current	Dldd	Current at pin 42 No signal	-	1.0	2.0	mA

**(2)Input / Output Characteristics ( Pin count base on 42pin version )**

Parameter	Symbol	Test condition	Limits			Unit
			Min	typ	Max	
Input resistance	Rin	13,15,16,17,27,29pin	35	70	150	KΩ
Maximum output voltage	VOM	6,8,9,11,13,15,16,17pin INPUT 31~36pin OUTPUT, THD=1%	3.0	4.2	-	Vrms
Pass gain	Gv	Vi=0.2Vrms,FLAT 6,8,9,11,13,15,16,17pin INPUT 31~36pin OUTPUT	-2.0	0	2.0	dB
Distortion	THD	BW=400~30kHz Vi=0.2Vrms,RL=10KΩ	-	0.004	0.09	%
Output noise voltage	Vn(VOL)	31~36pin JIS-A,VOL=0dB	-	4	6	μVrms
	Vn(tone)	31,32pin JIS-A,VOL=0dB	-	8	20	μVrms
Signal to noise ratio	S/N	all gains=0dB; Vo=1Vrms	-	98	105	dB
Maximum attenuation	ATTmax	31~36 pin JIS-A,VOL=-∞dB	-	-100	-95	dB
Volume gain between channels	Dvol		-1.5	0	1.5	dB
Crosstalk between channels	CT	Vo=0.5Vrms,RL=10KΩ, JIS-A, Rg=1KΩ	-	-100	-80	dB
Port output current	IL	RL=22KΩ	0.2	-	-	mA



**6 CHANNELS VOLUME CONTROLLER**

**(3) Tone Control Characteristics ( Pin count base on 42pin version )**

Parameter	Symbol	Test condition	Limits			Unit
			Min	typ	Max	
Tone control voltage gain	T -14dB	Vo=0.2Vrms,f=1kHz TREBLE(f=10kHz) BASS(f=100Hz)	-16	-14	-12	dB
	T -12dB		-14	-12	-10	dB
	T -10dB		-12	-10	-8	dB
	T -8dB		-10	-8	-6	dB
	T -6dB		-7.5	-6	-4.5	dB
	T -4dB		-5.5	-4	-2.5	dB
	T -2dB		-3	-2	-1	dB
	T +2dB	INPUT 13,15pin OUTPUT 31,32pin	1	2	3	dB
	T +4dB		2.5	4	5.5	dB
	T +6dB		4.5	6	7.5	dB
	T +8dB		6	8	10	dB
	T +10dB		8	10	12	dB
	T +12dB		10	12	14	dB
	T +14dB		12	14	16	dB
Balance between channel	BALT	Input pin13,15 Vo=0.2 Vrms,Output pin31,32	-1.5	0	+1.5	dB

**RECOMMENDED OPERATING CONDITIONS**

	Analog	Digital
Supply voltage range	$\pm 6.0 \sim \pm 8.0V$	4.5 ~ 5.5V
Rated supply voltage	$\pm 7.0V$	5.0V



6 CHANNELS VOLUME CONTROLLER

SIGNAL PROCESSING DIAGRAM

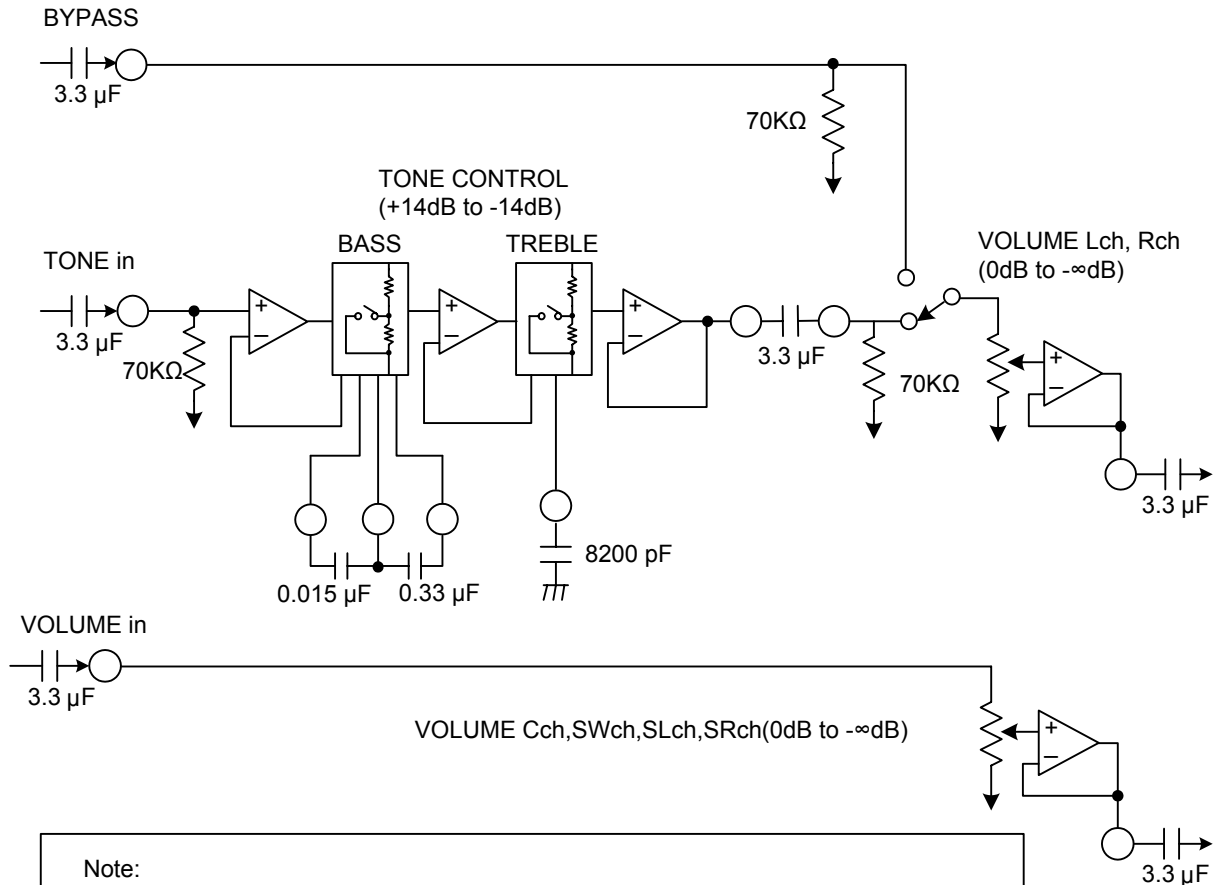

Note:

- (1) The resistance value of Volume change about 18 to 22KΩ by attenuated condition.
- (2) No built in a zero cross circuit.
- (3) When the mode changed (BYPASS/TONE), it is necessary the muting function.

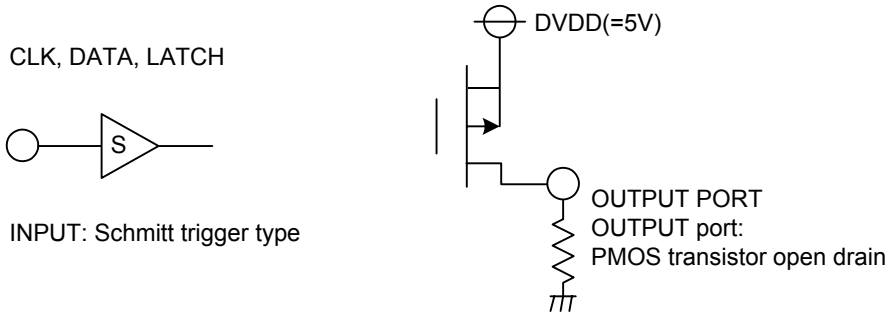



6 CHANNELS VOLUME CONTROLLER

APPLICATION EXAMPLE ( Pin count base on 44pin )

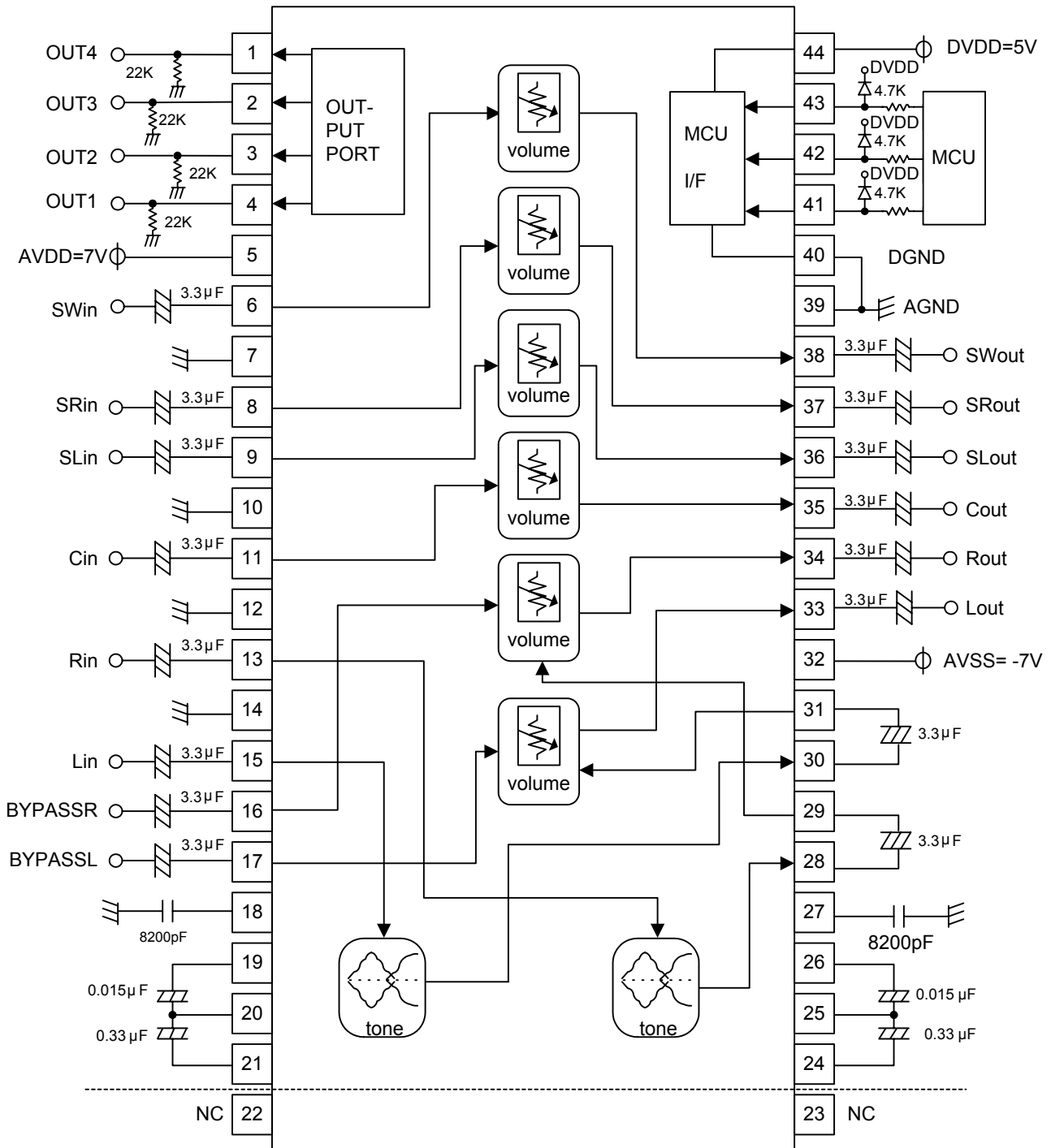

Units Resistance:Ω / Capacitance: F



6 CHANNELS VOLUME CONTROLLER

Figure1 : Tone Response of Treble

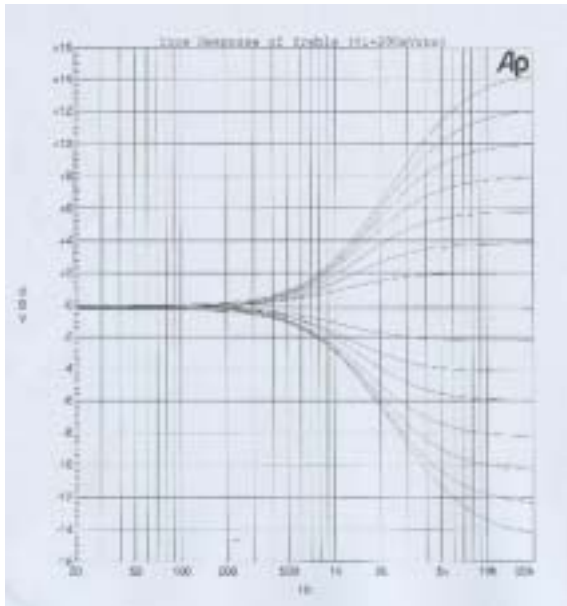

Figure2 : Tone Response of Bass

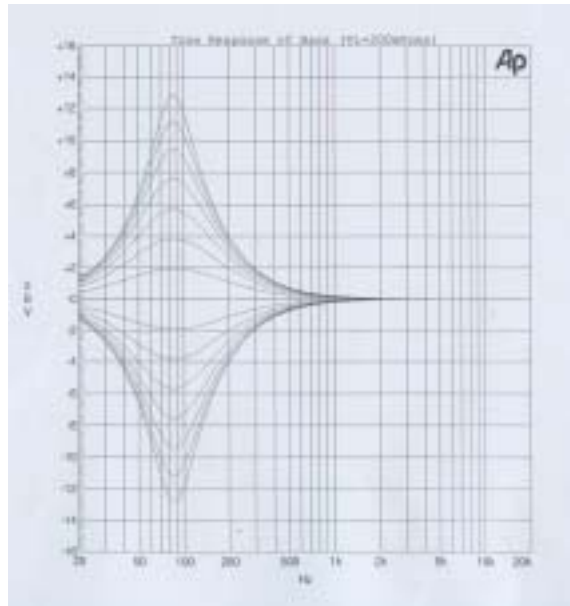

Figure3 : Crosstalk vs. R/L ch

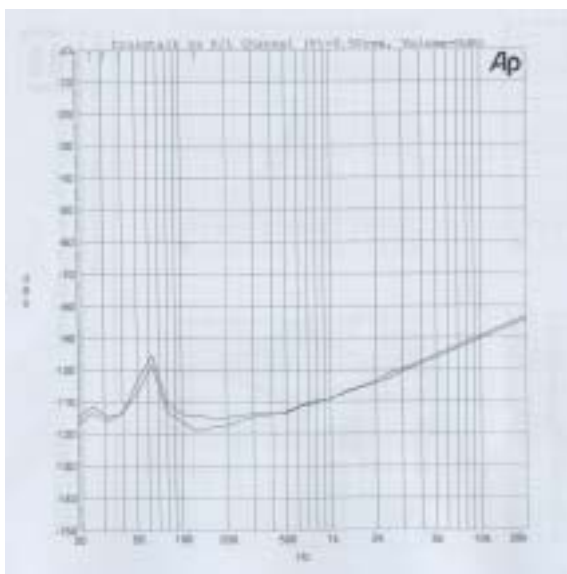
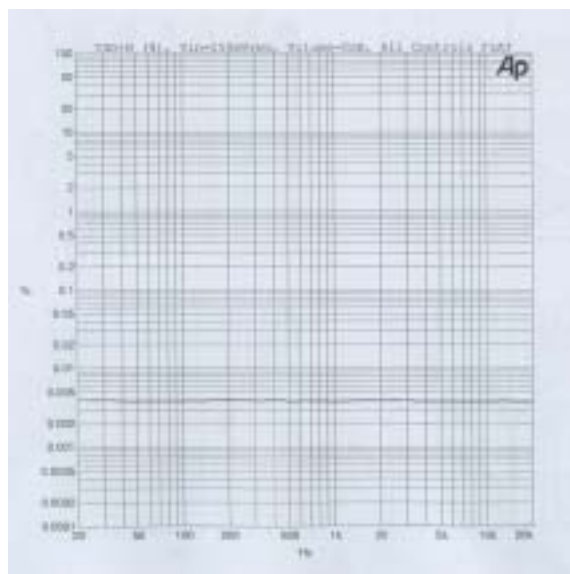

Figure4 : Distortion and Noise vs. Frequency  
(Vin=250mV,AV=0dB,ALL CONTROLS FLAT, VOLUME=0dB,-20dB)





6 CHANNELS VOLUME CONTROLLER

PACKAGE OUTLINE ( TSSOP44)

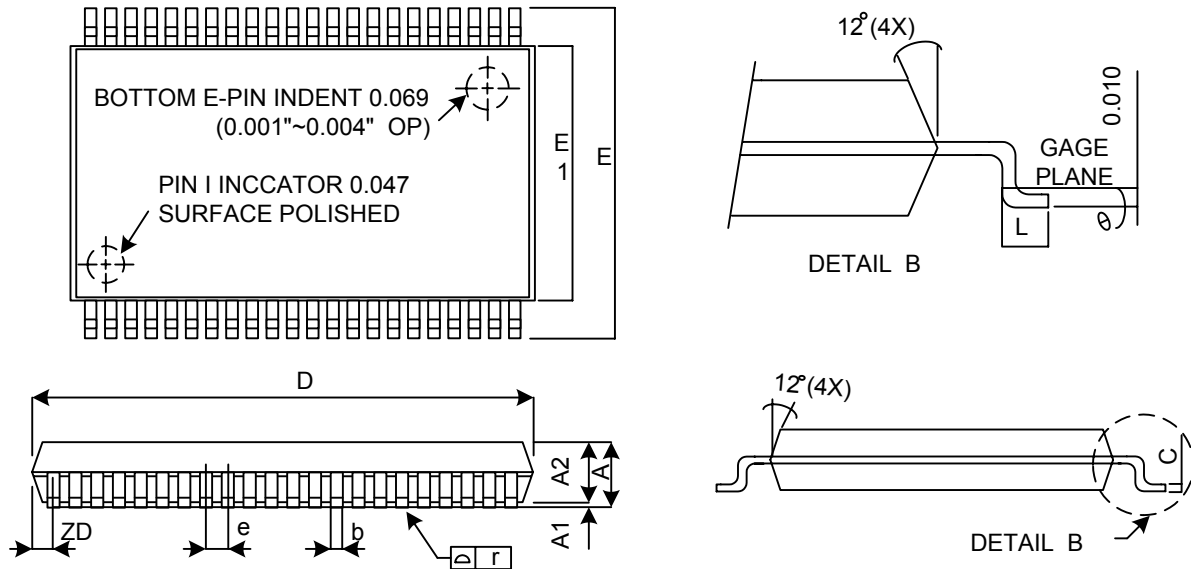

SYMBOLS	DIMENSIONS IN MILLIMETERS			DIMENSIONS IN INCHES		
	MIN	NOM	MAX	MIN	NOM	MAX
A	1.00	-	1.20	0.039	-	0.047
A1	0.05	-	0.15	0.002	-	0.006
A2	0.95	1.00	1.05	0.037	0.039	0.041
b	0.30	0.35	0.45	0.012	0.014	0.018
C	0.12	-	0.21	0.0047	-	0.0083
D	18.313	18.415	18.517	0.721	0.725	0.729
E	11.684	11.836	11.938	0.460	0.466	0.47
E1	10.058	10.160	10.262	0.396	0.400	0.404
e	-	0.800	-	-	0.315	-
L	0.40	0.50	0.60	0.0157	0.020	0.0236
ZD	-	0.805	-	-	0.0317	-
θ	0°	-	8°	0°	-	8°
y	0.00	-	0.076	0.000	-	0.003

NOTE:

1. CONTROLLING DIMENSION 1 INCH.
2. LEAD FRAME MATERIAL ALLOY 42.
3. DIMENSION "D" DOES NOT INCLUDE MOLD FLASH, THE BAR BURRS AND GATE BURRS. MOLD FLASH, THE BAR BURRS AND GATE BURRS SHALL NOT EXCEED 0.066"(0.15mm) PER END DIMENSION "E1" DOES NOT INCLUDE INTERLEAD FLASH. INTERLEAD FLASH NOT EXCEED 0.010" (0.25mm) PER SIDE.
4. DIMENSION "b" DOES NOT INCLUDE DAMBAR PROTRUSION. ALLOWABLE DAMBAR PROTRUSION SHALL BE 0.003"(0.08mm) TOTAL IN EXCESS OF THE "b" DIMENSION AT MAXIMUM MATERIAL CONDITION DAMBAR CANNOT BE LOCATED ON THE LOWER RADIUS OR THE FOOT. MINMUM SPACE BETWEEN PROTRUSION AND AN ADJACENT LEAD TO BE 0.0028"(0.07mm).
5. TOLERANCE +0.010"(0.25mm) UNLESS OTHERWISE SPECIFIED.
6. OTHERWISE DIMENSION FOLLOW ACCEPTABLE SPEC.
7. REFERENCE DOCUMENT: JEDEC SPEC MS-024.



**6 CHANNELS VOLUME CONTROLLER**

**PACKAGE OUTLINE ( SDIP42 )**

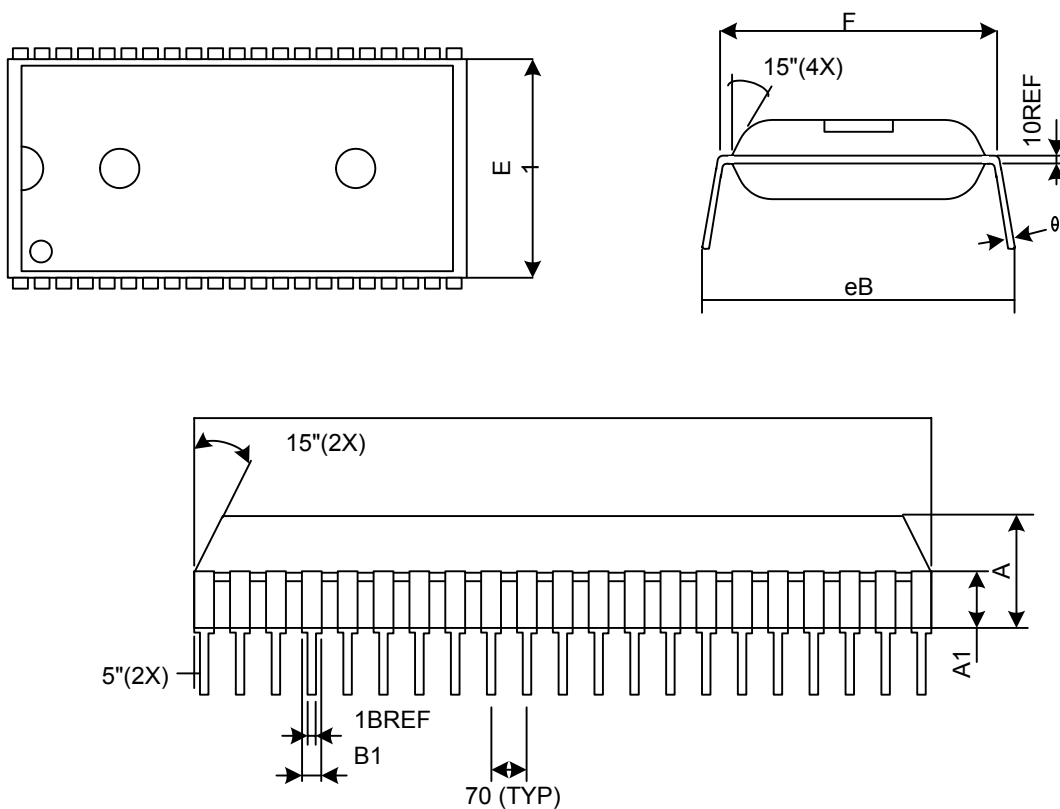

SYMBOL	Dimonation in mil			Dimenation in mm		
	MIN	NOM	MAX	MIN	NOM	MAX
A	155	160	165	3.937	4.064	4.2
A1	70	72.5	74	1.78	1.842	1.88
B1	36	40	44	0.914	1.270	1.118
D	1448	1450	1452	36.78	36.83	36.88
E1	549	550	551	13.945	13.970	13.998
F	592	800	608	15.037	15.240	15.443
eB	600	650	700	15.24	16.510	17.78
θ	0°	7.5°	15°	0°	7.5°	15°

PACKAGE OUTLINE DIMENSION FOR P-SDIP 42 PIN