



N-Channel Logic Level Enhancement Mode Field Effect Transistor

PRODUCT SUMMARY

V _{DSS}	I _D	R _{DS(ON)} (mΩ) Max
25V	12A	60 @ V _{GS} = 10V
		85 @ V _{GS} = 4.5V

FEATURES

- Super high dense cell design for low R_{DS(ON)}.
- Rugged and reliable.
- TO-252 and TO-251 Package.

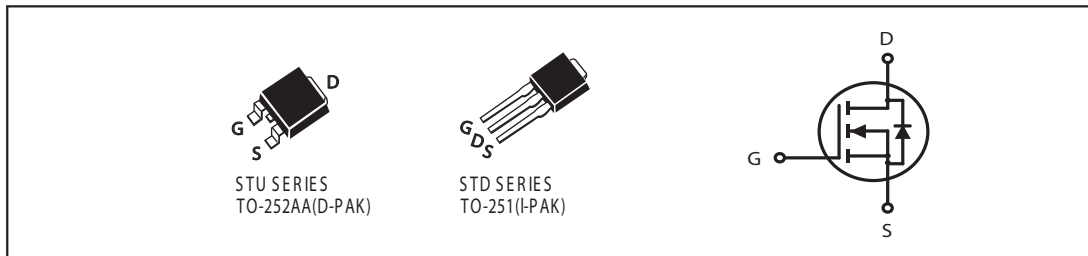
ABSOLUTE MAXIMUM RATINGS (T_A=25°C unless otherwise noted)

Parameter	Symbol	Limit	Unit
Drain-Source Voltage Rating	V _{spike} ^d	30	V
Drain-Source Voltage	V _{DS}	25	V
Gate-Source Voltage	V _{GS}	±16	V
Drain Current-Continuous @ T _C =25°C -Pulsed ^a	I _D	12	A
	I _{DM}	40	A
Drain-Source Diode Forward Current	I _S	5	A
Maximum Power Dissipation @ T _C =25°C	P _D	50	W
Operating and Storage Temperature Range	T _J , T _{STG}	-55 to 175	°C
THERMAL CHARACTERISTICS			
Thermal Resistance, Junction-to-Case	R _{θJC}	3	°C/W
Thermal Resistance, Junction-to-Ambient	R _{θJA}	50	°C/W

STU/D3055L

ELECTRICAL CHARACTERISTICS (T_A =25 °C unless otherwise noted)

Parameter	Symbol	Condition	Min	Typ ^c	Max	Unit
OFF CHARACTERISTICS						
Drain-Source Breakdown Voltage	BV _{DSS}	V _{GS} =0V, I _D =250uA	25			V
Zero Gate Voltage Drain Current	I _{DSS}	V _{DS} =20V, V _{GS} =0V			1	uA
Gate-Body Leakage	I _{GSS}	V _{GS} =±16V, V _{DS} =0V			±100	nA
ON CHARACTERISTICS^a						
Gate Threshold Voltage	V _{GS(th)}	V _{DS} =V _{GS} , I _D = 250uA	0.8	1.1	1.8	V
Drain-Source On-State Resistance	R _{DS(ON)}	V _{GS} =10V, I _D =4A		50	60	m-ohm
		V _{GS} =4.5V, I _D = 3A		62	85	m-ohm
On-State Drain Current	I _{D(ON)}	V _{DS} = 5V, V _{GS} = 4.5V	15			A
Forward Transconductance	g _{FS}	V _{DS} = 10V, I _D =5.0A		6		S
DYNAMIC CHARACTERISTICS^b						
Input Capacitance	C _{ISS}	V _{DS} =8V, V _{GS} = 0V f =1.0MHz		240	285	pF
Output Capacitance	C _{OSS}			97	113	pF
Reverse Transfer Capacitance	C _{RSS}			68	80	pF
SWITCHING CHARACTERISTICS^b						
Turn-On Delay Time	t _{D(ON)}	V _{DD} = 10V, I _D = 1A, V _{GEN} = 4.5V, R _L = 10 ohm R _{GEN} = 6 ohm		16.2	19.2	ns
Rise Time	t _r			18.4	21	ns
Turn-Off Delay Time	t _{D(OFF)}			10.1	11.5	ns
Fall Time	t _f			23.3	26	ns
Total Gate Charge	Q _g	V _{DS} =10V, I _D =4A, V _{GS} =10V		5.9	6.5	nC
		V _{DS} =10V, I _D =4A, V _{GS} =4.5V		3.2	3.5	nC
Gate-Source Charge	Q _{gs}	V _{DS} =10V, I _D = 4A, V _{GS} =10V		0.8	1	nC
Gate-Drain Charge	Q _{gd}			1.3	1.6	nC

STU/D3055L

ELECTRICAL CHARACTERISTICS ($T_A=25^\circ\text{C}$ unless otherwise noted)

Parameter	Symbol	Condition	Min	Typ ^c	Max	Unit
DRAIN-SOURCE DIODE CHARACTERISTICS ^a						
Diode Forward Voltage	V_{SD}	$V_{GS} = 0V, I_s = 5A$		1.0		V

Notes

- b.Pulse Test:Pulse Width $\leq 300\mu s$, Duty Cycle $\leq 2\%$.
- c.Guaranteed by design, not subject to production testing.
- d.Guaranteed when external $R_g=6\ \text{ohm}$ and $t_f < t_{f\ \text{max}}$

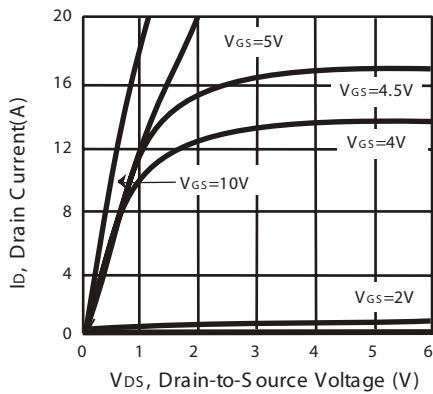

Figure 1. Output Characteristics

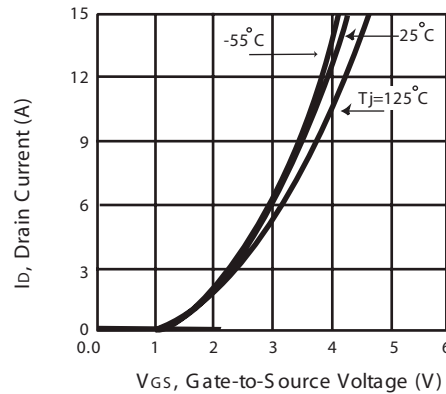

Figure 2. Transfer Characteristics

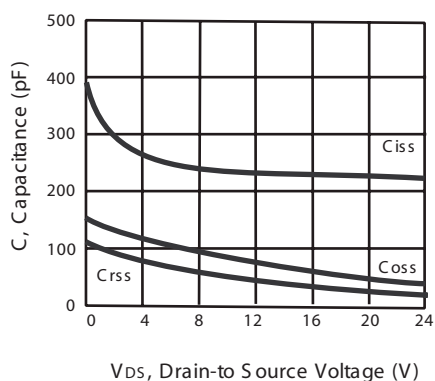

Figure 3. Capacitance

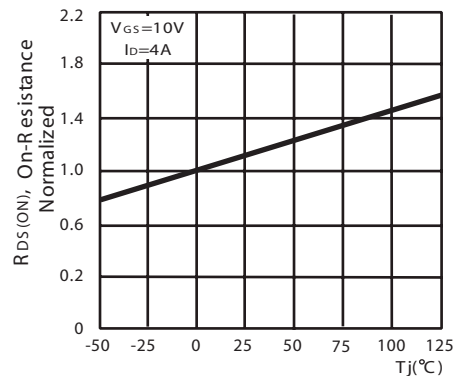

Figure 4. On-Resistance Variation with Temperature

STU/D3055L

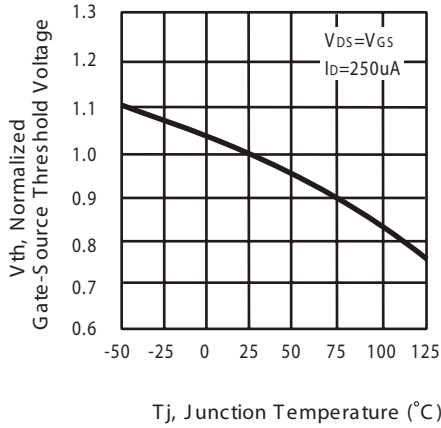

Figure 5. Gate Threshold Variation with Temperature

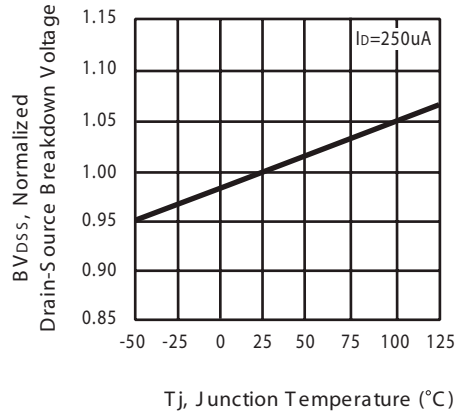

Figure 6. Breakdown Voltage Variation with Temperature

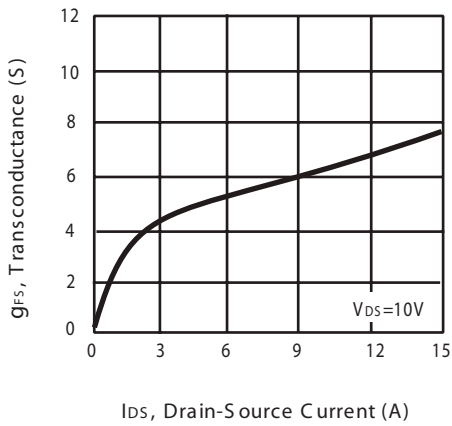

Figure 7. Transconductance Variation with Drain Current

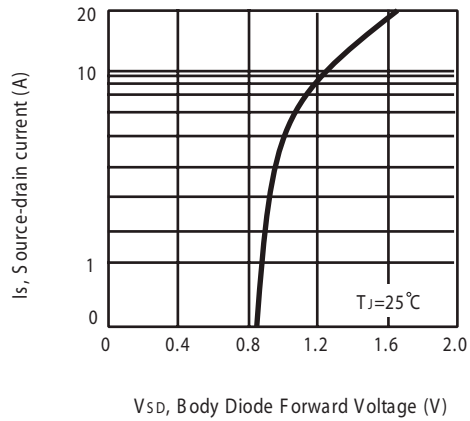

Figure 8. Body Diode Forward Voltage Variation with Source Current

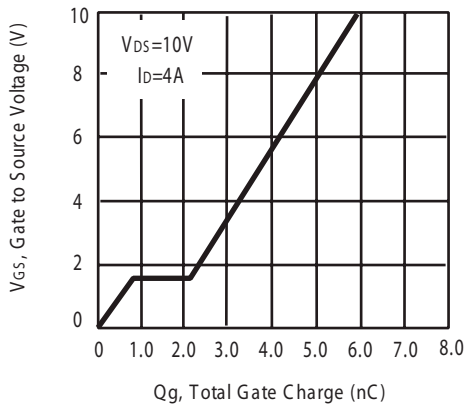

Figure 9. Gate Charge

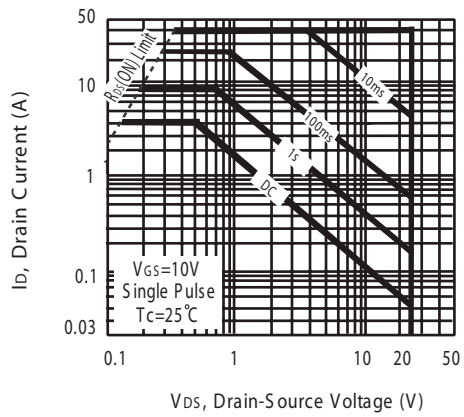

Figure 10. Maximum Safe Operating Area

STU/D3055L

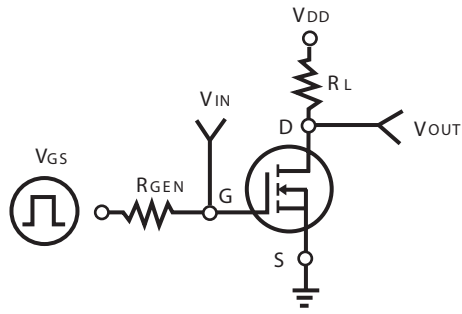

Figure 11. S Switching Test Circuit

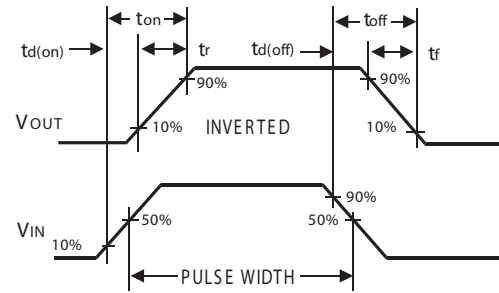

Figure 12. S Switching Waveforms

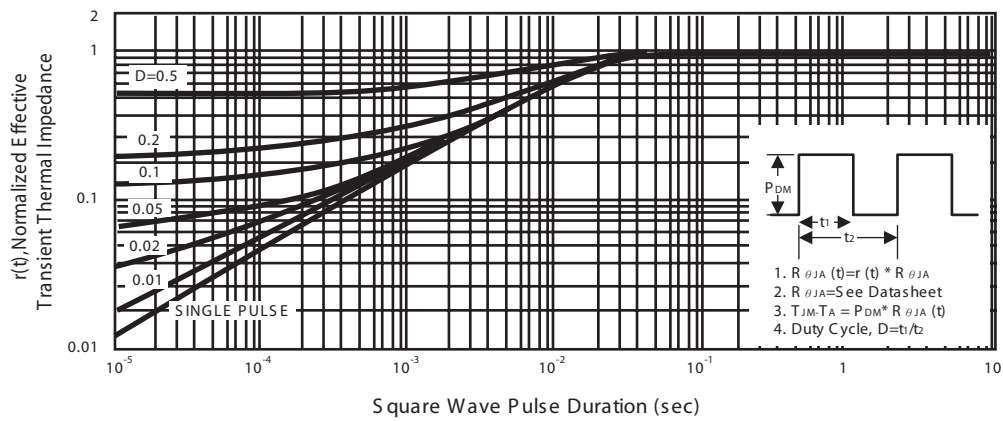
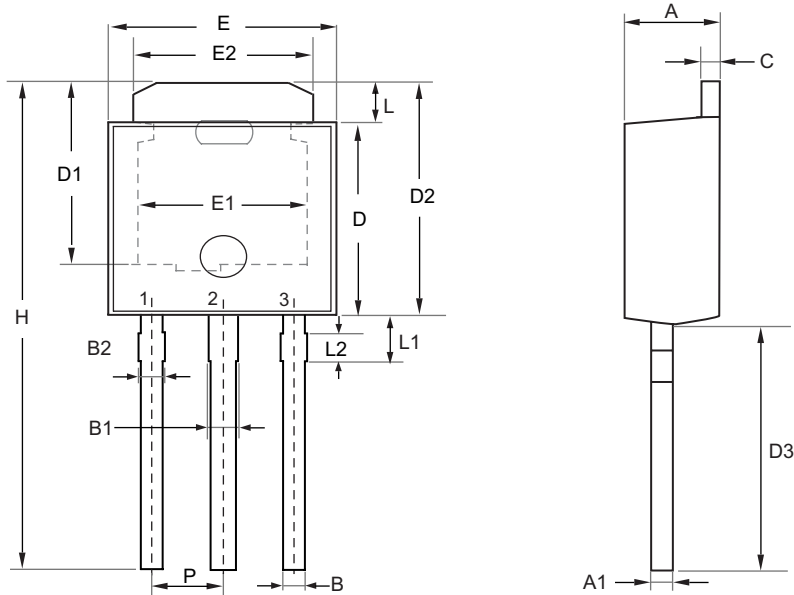

Figure 13. Normalized Thermal Transient Impedance Curve

STU/D3055L

PACKAGE OUTLINE DIMENSIONS

TO-251



SYMBOL	MILLIMETERS		INCHES	
	MIN	MAX	MIN	MAX
A	2.100	2.500	0.083	0.098
A1	0.350	0.650	0.014	0.026
B	0.400	0.800	0.016	0.031
B1	0.650	1.050	0.026	0.041
B2	0.500	0.900	0.020	0.035
C	0.400	0.600	0.016	0.024
D	5.300	5.700	0.209	0.224
D1	4.900	5.300	0.193	0.209
D2	6.700	7.300	0.264	0.287
D3	7.000	8.000	0.276	0.315
H	13.700	15.300	0.539	0.602
E	6.300	6.700	0.248	0.264
E1	4.600	4.900	0.181	0.193
E2	4.800	5.200	0.189	0.205
L	1.300	1.700	0.051	0.067
L1	1.400	1.800	0.055	0.071
L2	0.500	0.900	0.020	0.035
P	2.300 BSC		0.091 BSC	

STU/D3055L

PACKAGE OUTLINE DIMENSIONS

TO-252

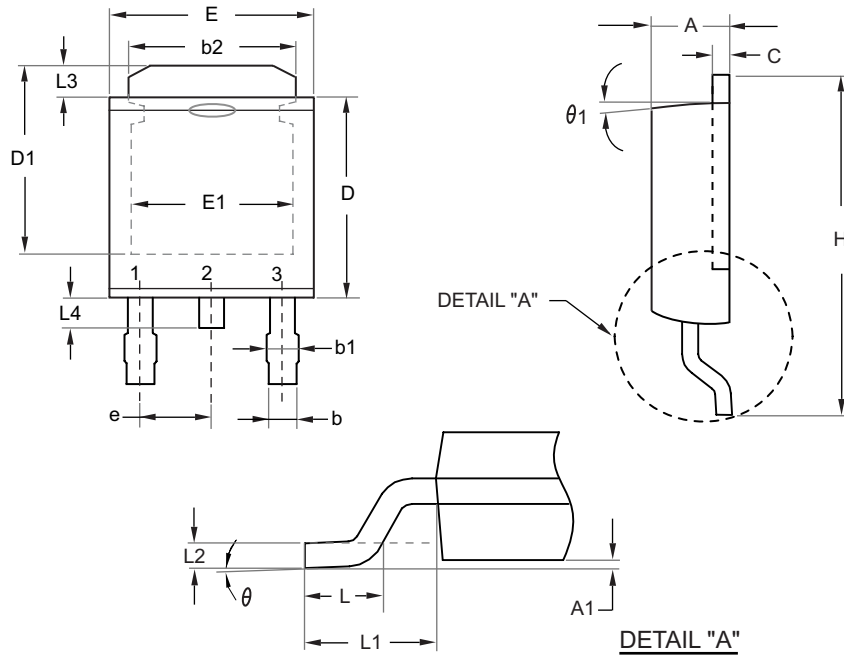

SYMBOLS	MILLIMETERS		INCHES	
	MIN	MAX	MIN	MAX
A	2.100	2.500	0.083	0.098
A1	0.000	0.200	0.000	0.008
b	0.400	0.889	0.016	0.035
b1	0.770	1.140	0.030	0.045
b2	4.800	5.460	0.189	0.215
C	0.400	0.600	0.016	0.024
D	5.300	6.223	0.209	0.245
D1	4.900	5.515	0.193	0.217
E	6.300	6.731	0.248	0.265
E1	4.400	5.004	0.173	0.197
e	2.290 REF		0.090 BSC	
H	8.900	10.400	0.350	0.409
L	1.397	1.770	0.055	0.070
L1	2.743 REF.		0.108 REF.	
L2	0.508 REF.		0.020 REF.	
L3	0.890	1.700	0.035	0.067
L4	0.500	1.100	0.020	0.043
θ	0°	10°	0°	10°
θ_1	7° REF.		7° REF.	

STU/D3055L

TO251 Tube/TO-252 Tape and Reel Data

TO-251 Tube

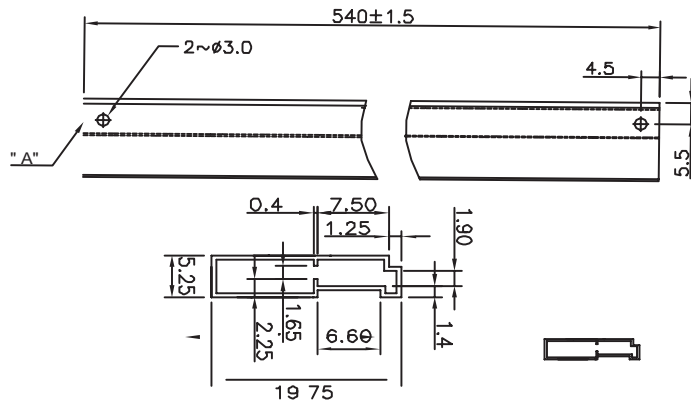

TO-252 Carrier Tape

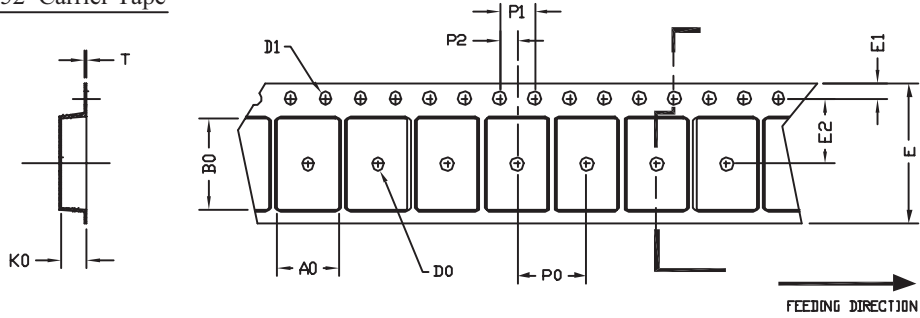

UNIT:mm

PACKAGE	A0	B0	K0	D0	D1	E	E1	E2	P0	P1	P2	T
TO-252 (16 mm)	6.80 ±0.1	10.3 ±0.1	2.50 ±0.1	φ2	φ1.5 +0.1 -0	16.0 0.3±	1.75 0.1±	7.5 ±0.15	8.0 ±0.1	4.0 ±0.1	2.0 ±0.15	0.3 ±0.05

TO-252 Reel

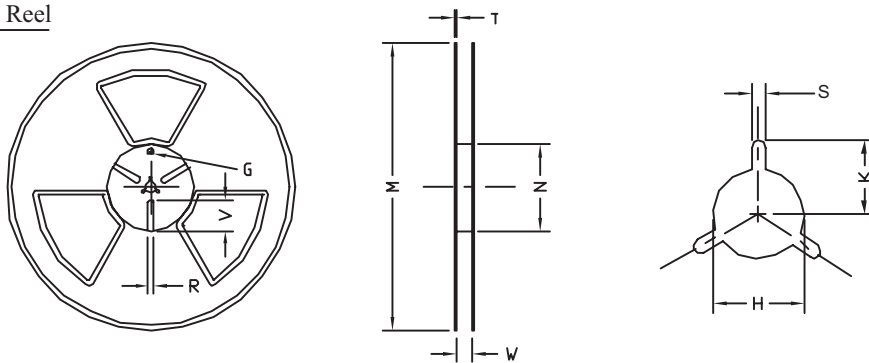

UNIT:mm

TAPE SIZE	REEL SIZE	M	N	W	T	H	K	S	G	R	V
16 mm	φ 330	φ 330 ± 0.5	φ 97 ± 1.0	17.0 + 1.5 - 0	2.2	φ 13.0 + 0.5 - 0.2	10.6	2.0 ±0.5	---	---	---