



N-Channel Enhancement Mode Field Effect Transistor

PRODUCT SUMMARY

V _{DS}	I _D	R _{DS(ON)} (Ω) Max
100V	1.2A	1.85 @ V _{GS} =10V
		2.3 @ V _{GS} =4.5V

FEATURES

- Super high dense cell design for low R_{DS(ON)}.
- Rugged and reliable.
- Surface Mount Package.
- ESD Protected.

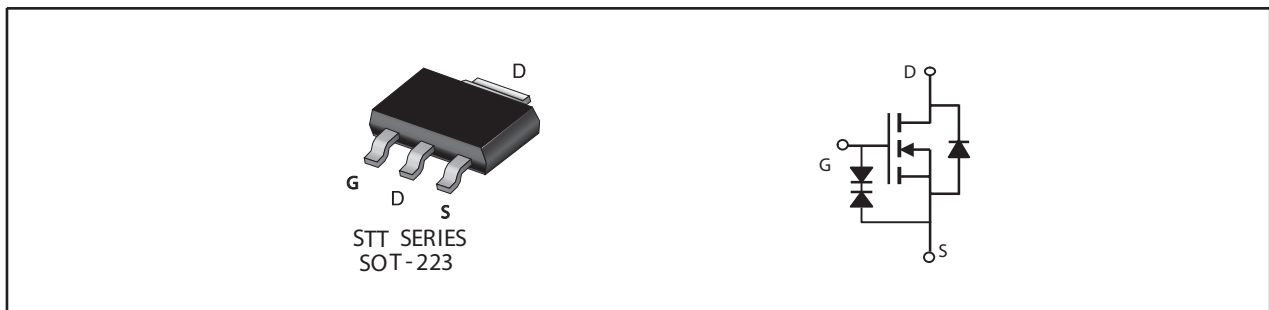

ABSOLUTE MAXIMUM RATINGS (T_A=25°C unless otherwise noted)

Symbol	Parameter	Limit	Units	
V _{DS}	Drain-Source Voltage ^d	100	V	
V _{GS}	Gate-Source Voltage	±20	V	
I _D	Drain Current-Continuous	T _A =25°C	1.2	A
		T _A =70°C	1.0	A
I _{DM}	-Pulsed ^a	8	A	
E _{AS}	Single Pulse Avalanche Energy ^c	1.56	mJ	
P _D	Maximum Power Dissipation	T _A =25°C	3	W
		T _A =70°C	1.9	W
T _J , T _{STG}	Operating Junction and Storage Temperature Range	-55 to 150	°C	

THERMAL CHARACTERISTICS

R _{θJA}	Thermal Resistance, Junction-to-Ambient ^a	42	°C/W
------------------	--	----	------

STT100

Ver 2.0

ELECTRICAL CHARACTERISTICS (TA=25°C unless otherwise noted)

Symbol	Parameter	Conditions	Min	Typ	Max	Units
OFF CHARACTERISTICS						
BV _{DSS}	Drain-Source Breakdown Voltage ^d	V _{GS} =0V , I _D =10mA	100			V
I _{DSS}	Zero Gate Voltage Drain Current	V _{DS} =80V , V _{GS} =0V			1	uA
I _{GSS}	Gate-Body Leakage Current	V _{GS} = ±20V , V _{DS} =0V			±10	uA
ON CHARACTERISTICS						
V _{GS(th)}	Gate Threshold Voltage	V _{DS} =V _{GS} , I _D =250uA	1	2.3	3	V
R _{DS(ON)}	Drain-Source On-State Resistance	V _{GS} =10V , I _D =0.6A		1.50	1.85	ohm
		V _{GS} =4.5V , I _D =0.5A		1.70	2.30	ohm
g _{FS}	Forward Transconductance	V _{DS} =10V , I _D =0.6A		1.3		S
DYNAMIC CHARACTERISTICS ^b						
C _{ISS}	Input Capacitance	V _{DS} =25V, V _{GS} =0V f=1.0MHz		69		pF
C _{OSS}	Output Capacitance			16.6		pF
C _{RSS}	Reverse Transfer Capacitance			8.2		pF
SWITCHING CHARACTERISTICS ^b						
t _{D(ON)}	Turn-On Delay Time	V _{DD} =50V I _D =0.6A V _{GS} =10V R _{GEN} = 6 ohm		8.8		ns
t _r	Rise Time			9		ns
t _{D(OFF)}	Turn-Off Delay Time			52		ns
t _f	Fall Time			11		ns
Q _g	Total Gate Charge	V _{DS} =50V, I _D =0.6A, V _{GS} =10V		1.9		nC
		V _{DS} =50V, I _D =0.6A, V _{GS} =4.5V		1.25		nC
Q _{gs}	Gate-Source Charge	V _{DS} =50V, I _D =0.6A,		0.55		nC
Q _{gd}	Gate-Drain Charge	V _{GS} =10V		0.67		nC
DRAIN-SOURCE DIODE CHARACTERISTICS AND MAXIMUM RATINGS						
V _{SD}	Diode Forward Voltage	V _{GS} =0V, I _S =0.1A		0.81	1.3	V
Notes a. Pulse Test: Pulse Width ≤ 300us, Duty Cycle ≤ 2%. b. Guaranteed by design, not subject to production testing. c. Starting T _J =25°C, L=0.5mH, V _{DD} = 45V. (See Figure13) d. Pulse Test: Pulse Width ≤ 1us, Duty Cycle ≤ 1%.						

Nov,04,2011

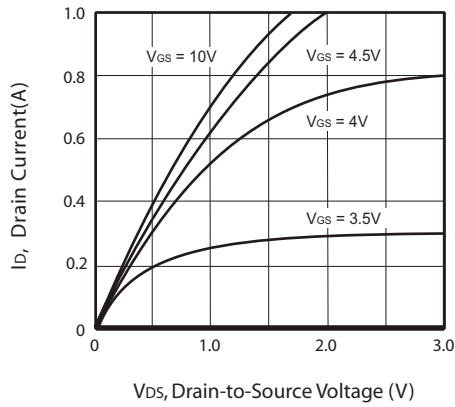

Figure 1. Output Characteristics

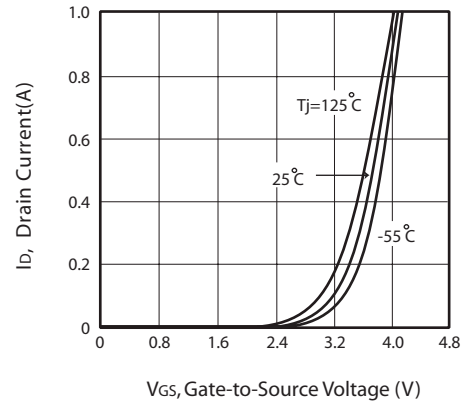

Figure 2. Transfer Characteristics

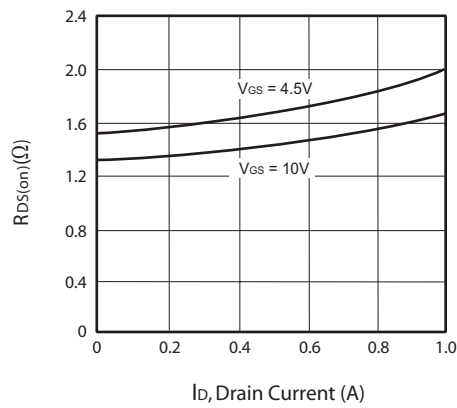

Figure 3. On-Resistance vs. Drain Current and Gate Voltage

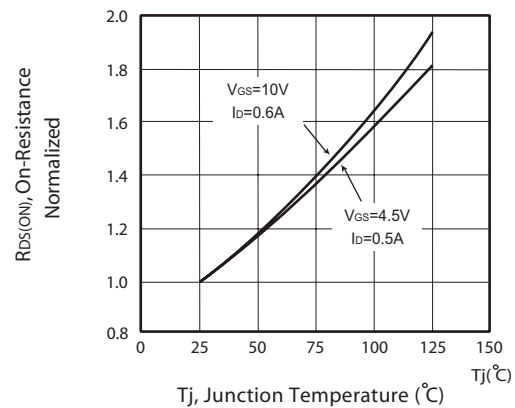

Figure 4. On-Resistance Variation with Drain Current and Temperature

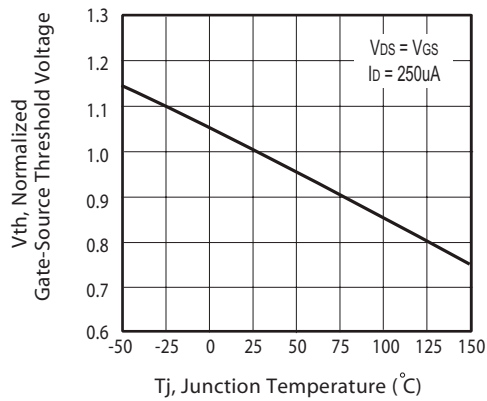

Figure 5. Gate Threshold Variation with Temperature

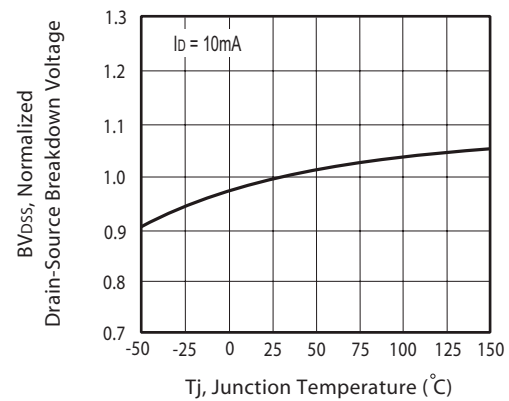

Figure 6. Breakdown Voltage Variation with Temperature

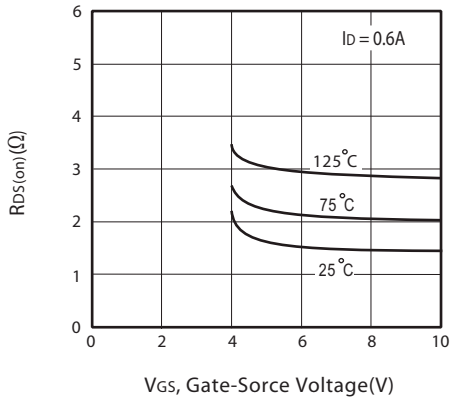

Figure 7. On-Resistance vs. Gate-Source Voltage

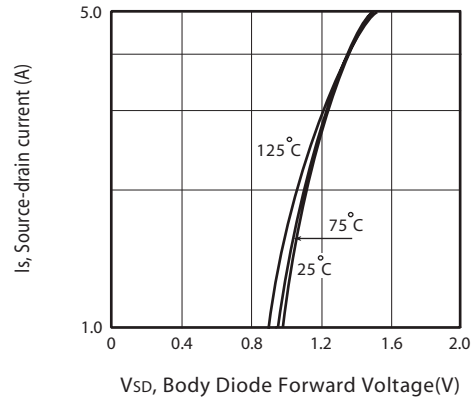

Figure 8. Body Diode Forward Voltage Variation with Source Current

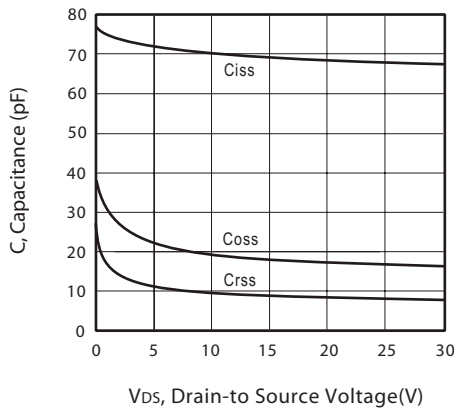

Figure 9. Capacitance

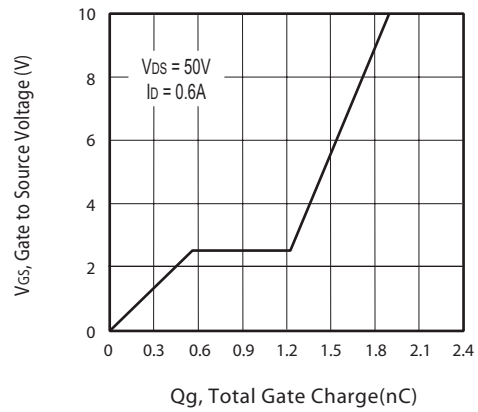

Figure 10. Gate Charge

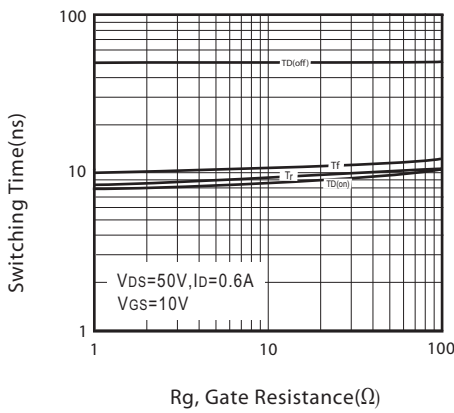

Figure 11. switching characteristics

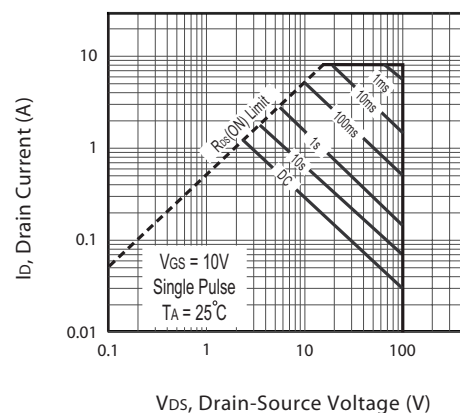
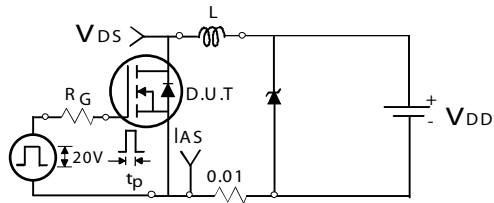
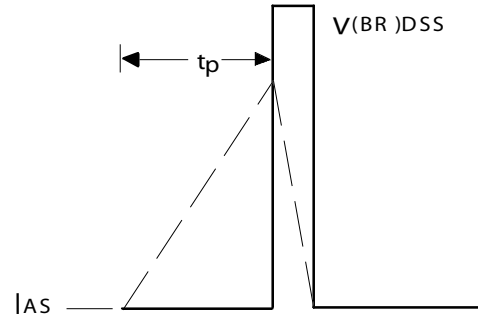

Figure 12. Maximum Safe Operating Area



Unclamped Inductive Test Circuit

Figure 13a.



Unclamped Inductive Waveforms

Figure 13b.

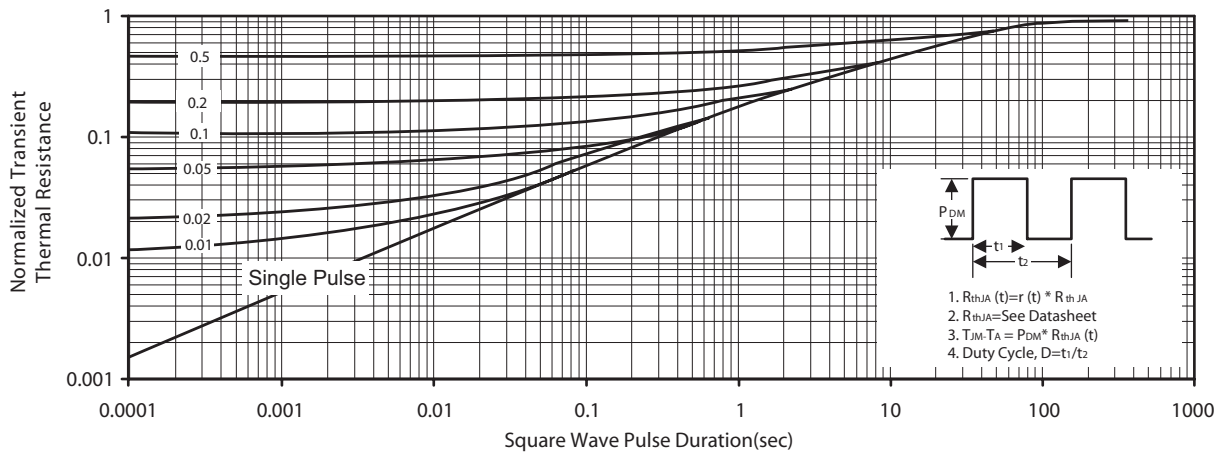
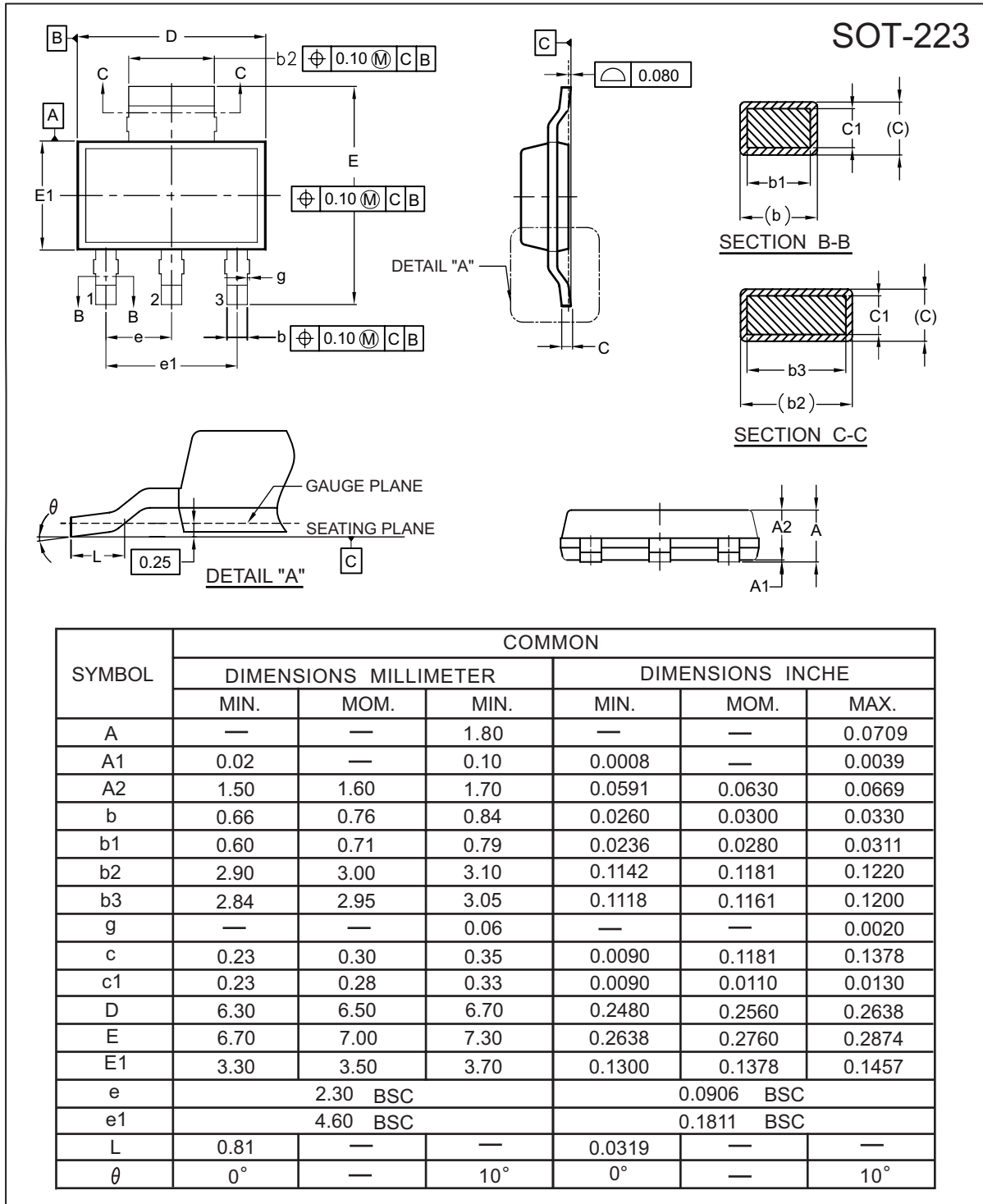
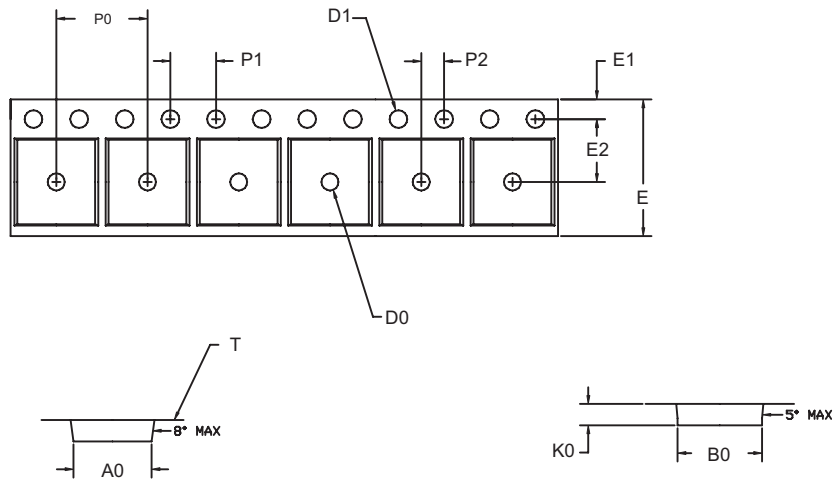

Figure 14. Normalized Thermal Transient Impedance Curve



SOT-223 Tape and Reel Data

SOT-223 Carrier Tape



unit:mm

PACKAGE	A0	B0	K0	D0	D1	E	E1	E2	P0	P1	P2	T
---	6.83 ±0.1	7.42 ±0.1	1.88 ±0.1	1.50 +0.25	1.60 +0.1	12.0 +0.3 -0.1	1.75 ±0.1	5.50 ±0.5	8.0 ±0.1	4.00 ±0.1	2.00 ±0.05	0.292 ±0.02

SOT-223 Reel

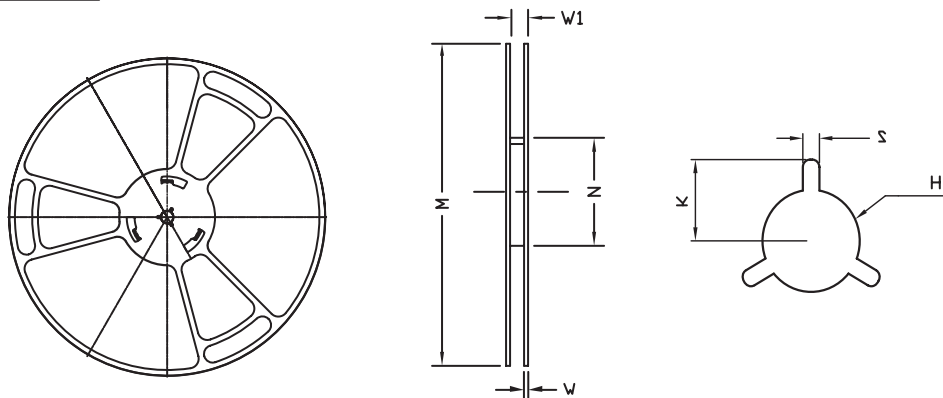

UNIT:mm

REEL SIZE	M	N	W	W1	H	K	S	G	R	V
φ 330 ± 0.5	---	φ 97.0 ± 1.0	2.2	13.0 + 1.5	φ 13.0 + 0.5 - 0.2	10.6	2.0 ± 0.5	---	---	---