



三合微科股份有限公司  
SAMHOP Microelectronics Corp.

---

# SM5172

**3<sup>12</sup> RF DECODER**

**REV. 1.01**

**APRIL 12, 2004**

**The information in this document is subject to change without notice.  
© SAMHOP Microelectronics Corp. All Rights Reserved.**

---

台北縣新店市民權路100號7樓  
7F, No.100, Min-Chyuan Road, Hsintien, Taipei Hsien, Taiwan, R.O.C.  
TEL: 886-2-2218-3978/2820 FAX: 886-2-2218-3320  
Email : [info@samhop.com.tw](mailto:info@samhop.com.tw)



**3<sup>12</sup> RF DECODER**

**GENERAL DESCRIPTION**

SM5172 is a remote control decoder paired with SM5162 utilizing CMOS Technology. It has 12-bit tri-state address pins providing a maximum of 531,411 (or 3<sup>12</sup>) address codes; thereby, drastically reducing any code collision and unauthorized code scanning possibilities. SM5172 is available in several options to suitable every application needs : variable number of data output pins, latch or momentary output type.

**FEATURES**

- \* CMOS Technology
- \* Low power consumption
- \* Very high noise immunity
- \* Up to 12 tri-State code address pins
- \* Up to 6 data pins
- \* Wide range of operating voltage:  
Vcc= 3 ~ 12 Volts
- \* Single resistor oscillator
- \* Latch or momentary output type
- \* Available in DIP and SOP package

**APPLICATIONS**

- \* Car security
- \* Garage door
- \* Home security/Automation system
- \* Toys
- \* Remote control for industrial use

**BLOCK DIAGRAM**

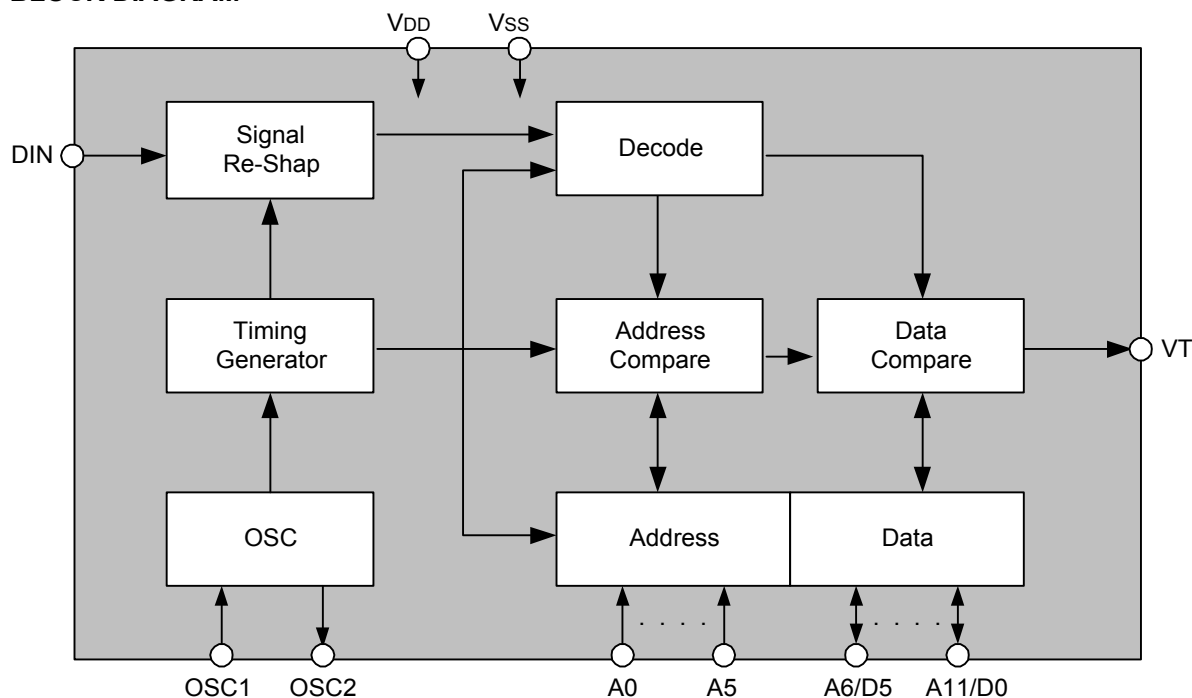



3<sup>12</sup> RF DECODER

PIN ASSIGNMENTS ( DIP )

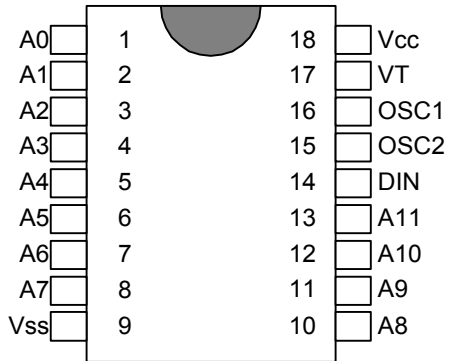

SM5172

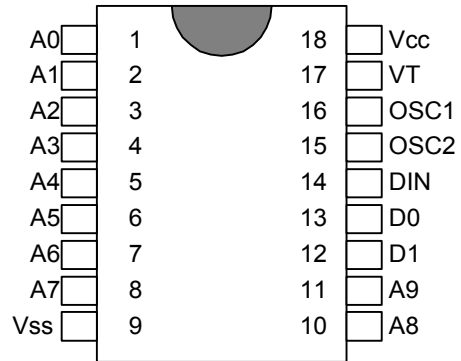

SM5172-M2/L2

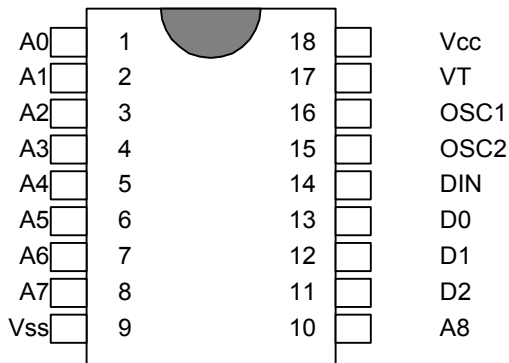

SM5172-M3/L3

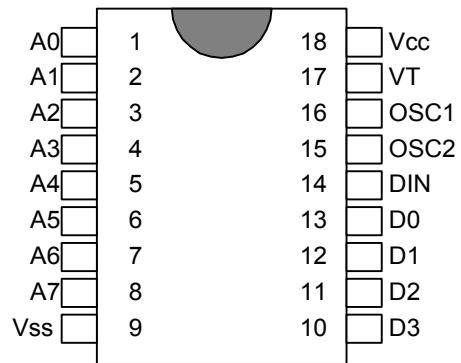

SM5172-M4/L4

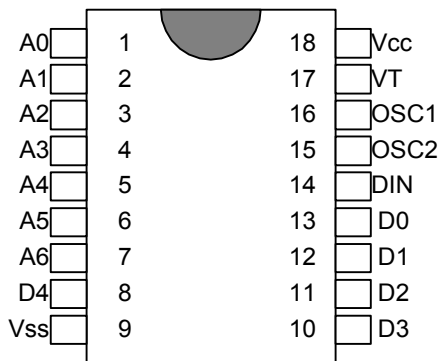

SM5172-M5/L5

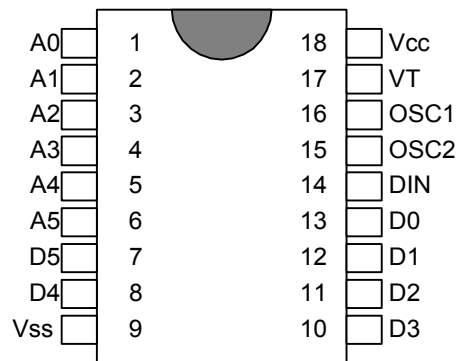

SM5172M6/L6



3<sup>12</sup> RF DECODER

PIN CONFIGURATION ( SOP )

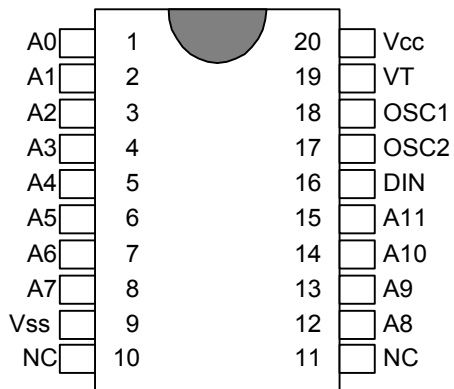

SM5172S

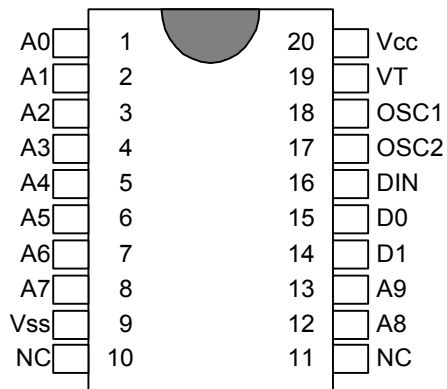

SM5172S-M2/L2

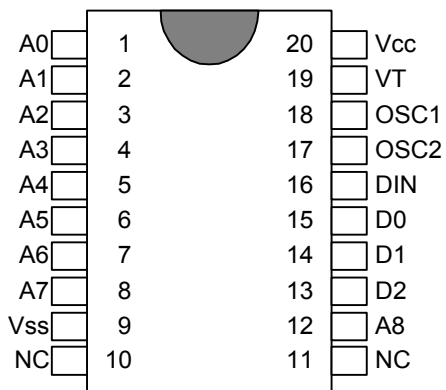

SM5172S-M3/L3

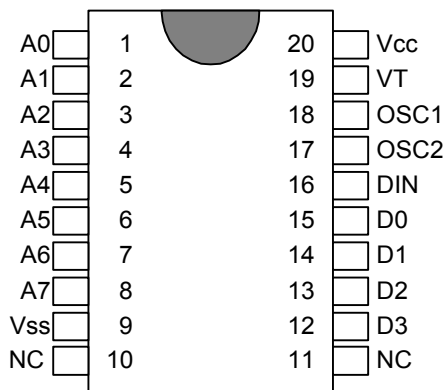

SM5172S-M4/L4

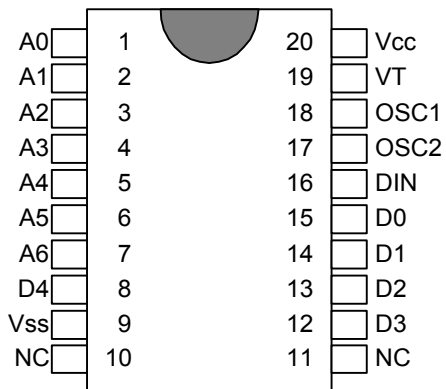

SM5172S-M5/L5

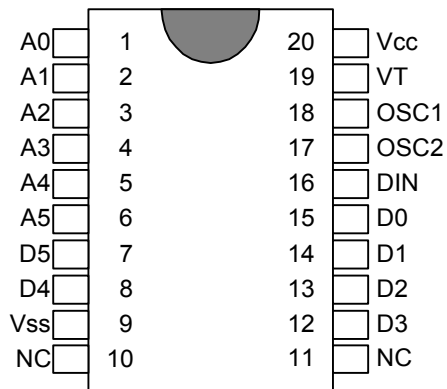

SM5172S-M6/L6

**3<sup>12</sup> RF DECODER****PIN DESCRIPTION**

No.	Pin Name	I/O	Function
1	A0	I	Address input, each pin can be set to "0", "1" , or floating.
2	A1	I	
3	A2	I	
4	A3	I	
5	A4	I	
6	A5	I	
7	A6/D5	I / O	Address input or data output.
8	A7/D4	I / O	
9	Vss	POWER	Negative power supply.
10	A8/D3	I / O	Address input or data output.
11	A9/D2	I / O	
12	A10/D1	I / O	
13	A11/D0	I / O	
14	DIN	I	Receive from RF module.
15	OSC2	O	Resistor connected between these two pins determine the system clock.
16	OSC1	I	
17	VT	O	Valid transmission indication.
18	VDD	POWER	Positive power supply.



---

**3<sup>12</sup> RF DECODER**

---

**Code Word**

A group of Code Bits is called a Code Word. A Code Word consists of 12 Address plus Data bits followed by one Sync Bit. The 12 AD bits are interpreted as either address or data bits depending on the SM5172 version used. Please refer to the diagrams below:

**SM5172**



**SM5172-M2/L2**



**SM5172-M3/L3**



**SM5172-M4/L4**

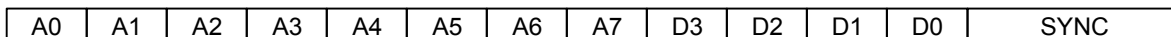

**SM5172-M5/L5**



**SM5172-M6/L6**

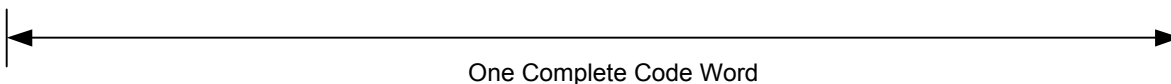



3<sup>12</sup> RF DECODER

Valid Transmission

After Power On SM5172 enters the search Address mode, if SM5172 finds 2 consecutive Address that matches the Address Pin setting of SM5172 then it will set VT high.

If VT is set high, SM5172 is still in search Address. After 2 consecutive Address that do not match the setting on SM5172, SM5172 will disable VT.

The timing are shown in the following diagram.

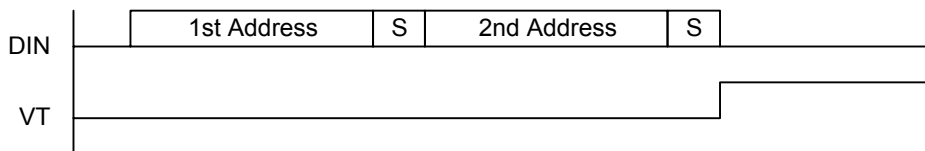

Latch or Momentary Data Output Type

After Power On SM5172 is set in search Address mode, if SM5172 finds 2 consecutive Address that matches the Address setting of SM5172. SM5172 will enter DataCompare mode. It will compare perviously 2 receive data, if they match each then SM5172 will set VT high and send data O/P.

SM5172 re-enters search Address mode, after 2 consecutive Address that do not math the setting on SM5172 will disable VT and momentary's data but keep Latch's data intact.

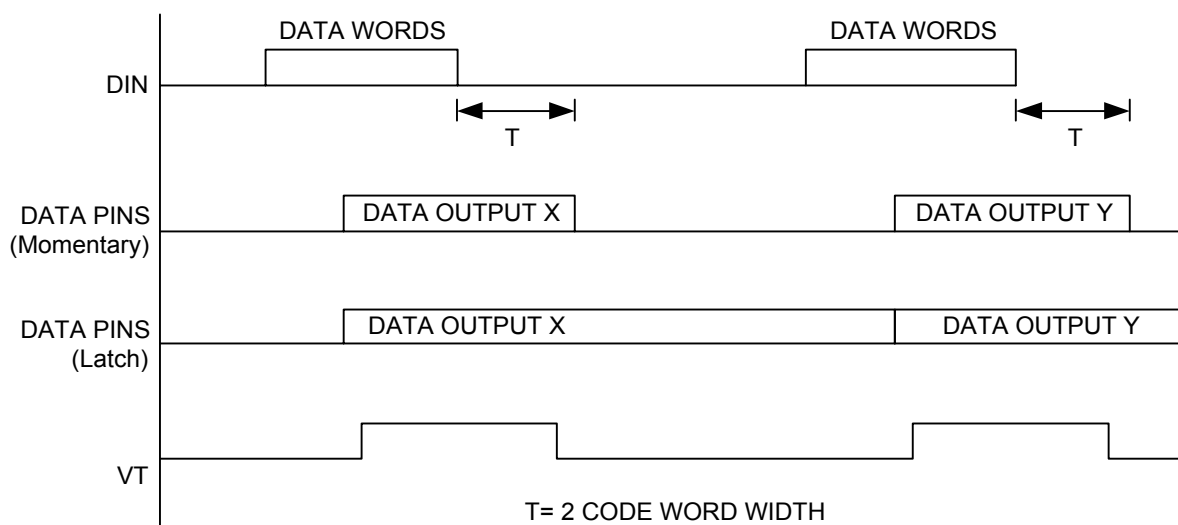



3<sup>12</sup> RF DECODER

OPERATION FLOWCHART

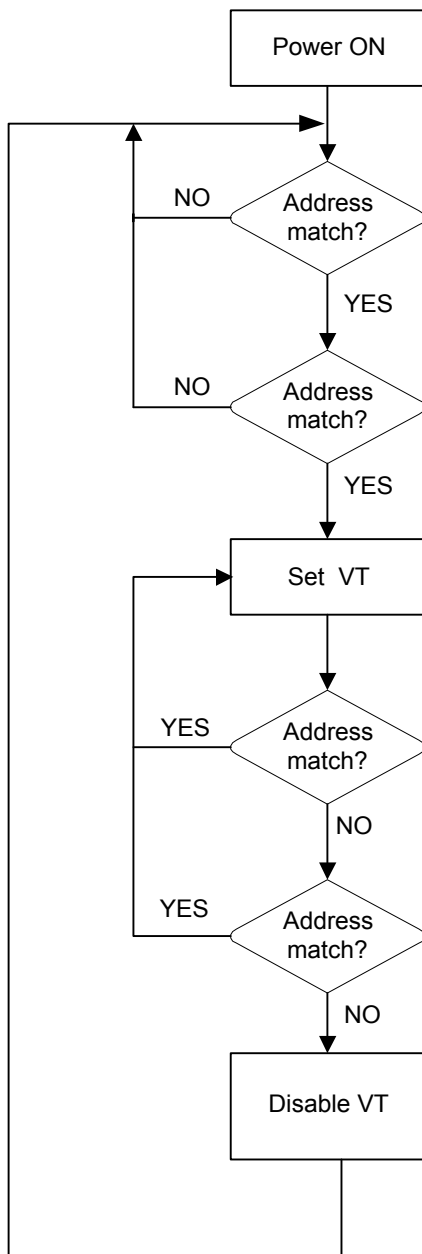

After Power On SM5172 enters the search Address mode, if SM5172 finds 2 consecutive Address that matches the Address Pin setting of SM5172, it will set VT high.

If VT is set high, SM5172 is still in search Address. After 2 consecutive Address that do not match the setting on SM5172, SM5172 will disable VT.



3<sup>12</sup> RF DECODER

DECODER WITH DATA OUTPUT PINS

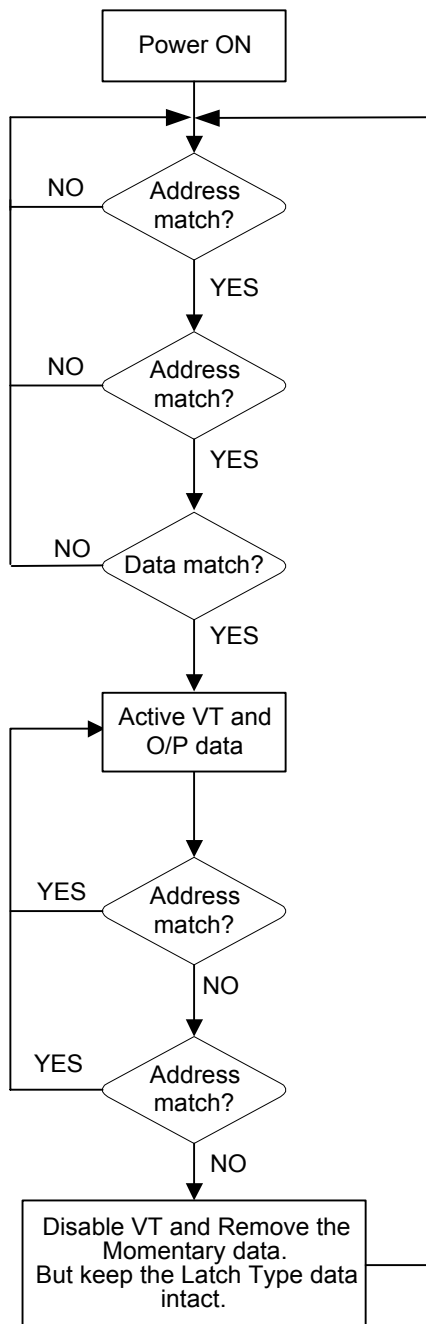

After Power On SM5172 is set in Address search mode, if SM5172 finds 2 consecutive Address that matches the Address setting of SM5172. SM5172 will enter Data Compare mode. It will compare previously 2 received data, if they match then SM5172 will set VT high and send data O/ P.

SM5172 re-enters Address search mode, after 2 consecutive Address that do not match setting on SM5172 will disable VT and momentary's data but keep Latch's data intact.



**3<sup>12</sup> RF DECODER**

**Single Resistor Oscillator**

SM5172's oscillator be constructed by connecting a resistor between OSC1 and OSC2 pin. SM5172's OSC frequency must be 1.8 to 5.8 ratio more than SM5162.

Encoder OSC Frequency (SM5162)

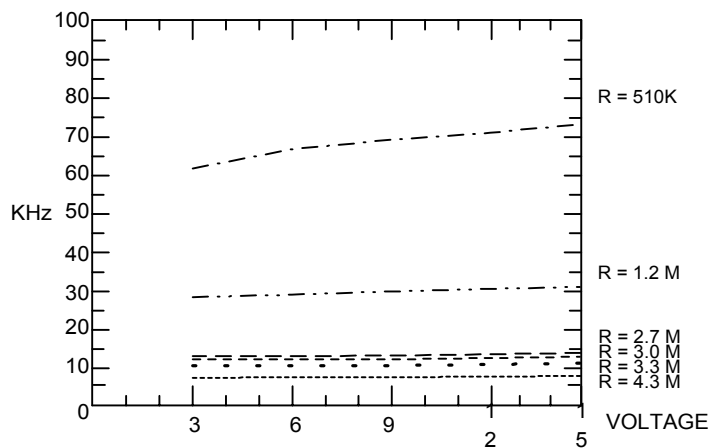

Dncoder OSC Frequency (SM5172)

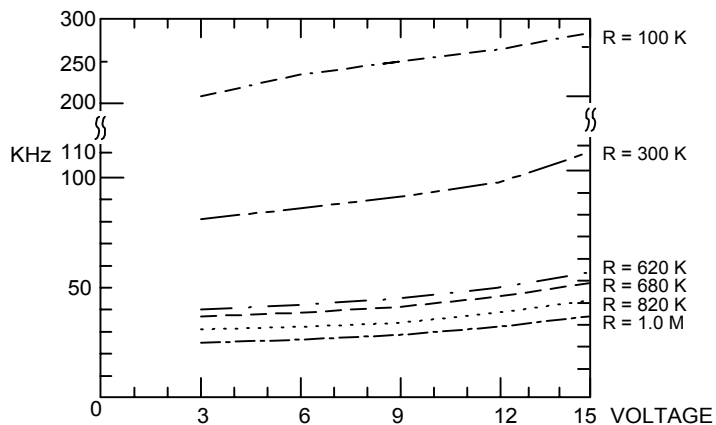

Suggested oscillator resistor of SM5162/ SM5172:

SM5162 (Encoder)	SM5172 (Decoder)
4.7M $\Omega$	820K $\Omega$
3.0M $\Omega$	620K $\Omega$
2.2M $\Omega$	300K $\Omega$
1.2M $\Omega$	180K $\Omega$

**3<sup>12</sup> RF DECODER****DC ELECTRICAL CHARACTERISTICS**

Parameter	Symbol	Conditions	Limit			Unit
			Min.	Typ.	Max.	
Supply Voltage	V <sub>CC</sub>		3		12	V
Standby Current	I <sub>STB</sub>	V <sub>CC</sub> = 12 V OSC stop A0 ~ A11 open		0.02	0.3	μA
Data Output Driving Current	I <sub>OH</sub>	V <sub>CC</sub> = 5V V <sub>OH</sub> = 4V	-4			mA
		V <sub>CC</sub> = 8V V <sub>OH</sub> = 6.4V	-8			mA
		V <sub>CC</sub> = 12V V <sub>OH</sub> = 9.6V	-15			mA
Data Output Sinking Current	I <sub>OL</sub>	V <sub>CC</sub> = 5V V <sub>OH</sub> = 1V	6			mA
		V <sub>CC</sub> = 8V V <sub>OH</sub> = 1.6V	14			mA
		V <sub>CC</sub> = 12V V <sub>OH</sub> = 2.4V	26			mA



3<sup>12</sup> RF DECODER

APPLICATION CIRCUIT

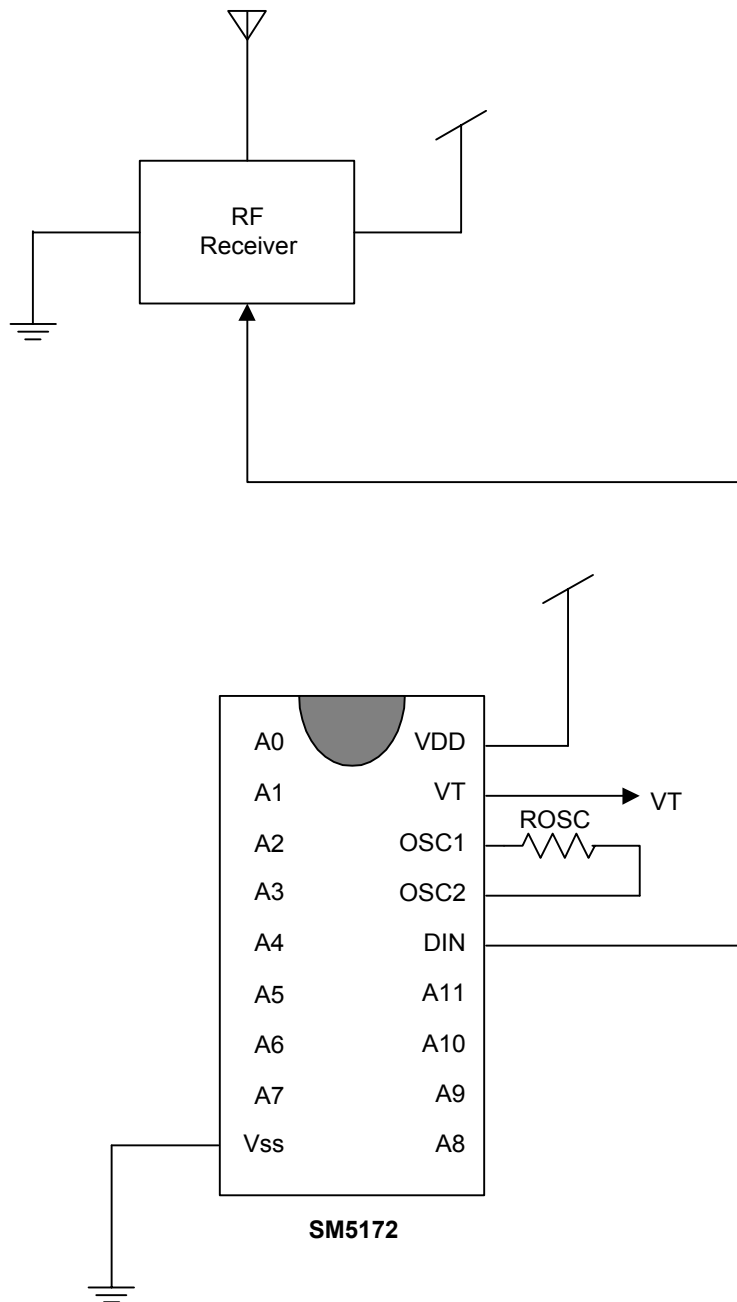



3<sup>12</sup> RF DECODER

ORDERING INFORMATION

Part No.	Package
SM5172	18 Pin DIP

Part No.	Package
SM5172S	20 Pin SOP

